



LE PIETRE INCISE - LE PIETRE INCISE PALLADIO - NUANCE - LE PIETRE LUMINOSE





design raffaello galiotto



E' la passione di due giovani fratelli, Claudio e Alberto Bevilacqua, che fa nascere Lithos Design sull'onda dell'esperienza di un'azienda di famiglia che vanta 30 anni di storia, è l'incontro con il designer Raffaello Galiotto che imprime il marchio estetico all'azienda: Lithos Design, produttore italiano di rivestimenti, pareti divisorie e pavimenti in pietra naturale di design industriale per la decorazione d'interni, nasce nel 2007 ed è già oggi riconosciuto a livello internazionale per design, innovazione e qualità tipiche del made in Italy. Soprattutto, è una delle prime aziende che hanno introdotto il concetto di industrial design litico.

L'ingrediente principale di questo successo è, naturalmente, la pietra. Come per ogni materiale naturale, il suo fascino è legato all'irripetibilità, ancor più valorizzata nell'incontro inusuale con l'industrializzazione e la produzione seriale. Ogni modello nasce all'interno del laboratorio di Lithos Design in collaborazione con il designer: si seleziona il tipo di marmo, la tecnologia è plasmata per entrare in massima sintonia con la pietra e svelarne la bellezza più nascosta, ricerche complementari sono svolte in ambiti diversi dal litico, come l'illuminotecnica. Il risultato è un'offerta inedita di soluzioni architettoniche modulari e pronte all'uso, realizzate nel più durevole dei materiali naturali, con tecniche di produzione che rispettano massimamente l'ambiente. Soluzioni a disposizione del progettista, che i grandi della progettazione a livello internazionale stanno scegliendo fin dalle nostre origini.

Dal 2016 Lithos Design cambia anche volto, e la vision aziendale si traduce in un'emoticon e un nuovo logo, disegnato da Raffaello Galiotto e declinato per le diverse divisioni aziendali, il cui elemento unificante è il monogramma LD proposto in forma di smiley. Questo volto che ride apertamente diviene l'icona del primo valore con cui l'Azienda affronta le sfide del mercato: il potere della risata intelligente che sa accendere la creatività nelle sue più potenti forme espressive.

*The passion of two young brothers, Claudio and Alberto Bevilacqua, lies behind the establishment of Lithos Design on the experience of a family-run business boasting 30 years of history; the encounter with designer Raffaello Galiotto marked the Company's styling brand: Lithos Design, Italian producer of coverings, partition walls and natural stone flooring for interiors, was established in 2007 and is already well known across the globe for its design, innovation and quality standards epitomising the "Made in Italy" trademark. Most of all, it is one of the leading companies who introduced the concept of industrial stone design.*

*The main ingredient for this success is obviously stone. Like all natural materials, its appeal is linked to its uniqueness, further emphasised here by the unusual merger with industrialisation processes and mass production. Each model is born in the Lithos Design laboratory in collaboration with the designer: the type of marble is chosen, technology is plied to achieve a perfect marriage with stone and reveal its most hidden beauty, at times performing additional research in areas other than stone design, such as lighting technology. The result is an unprecedented offering of modular architectural solutions that are ready for use, at the complete disposal of designers, that the best design firms worldwide are choosing since the beginning of our story.*

*From 2016, Lithos Design also changes its face: its business vision is translated into an emoticon and a new logo, designed by Raffaello Galiotto and declined for the three different business divisions, whose common element is the monogram LD presented in the form of a smiley. This laughing-out-loud face becomes the icon of the first value that the Company uses to tackle market challenges: the power of laughing with intelligence, which stirs creativity to express itself at its best.*

## NATURAL THINKING

Lithos Design ha scelto di lavorare solo con pietra naturale, pietre calcaree o arenarie e marmi. Non utilizza pietre agglomerate, ricostituite o sintetiche. Le pietre naturali, soprattutto se utilizzate come rivestimento, richiedono poca manutenzione e conservano nel tempo la loro naturale bellezza. L'utilizzo dei rivestimenti in pietra contribuisce alla salubrità e alla sicurezza degli ambienti: le pietre naturali non sono infiammabili, non si caricano elettrostaticamente, non favoriscono lo sviluppo di microrganismi batterici e muffe. I rivestimenti in pietra di Lithos Design, inoltre, presentano interessanti proprietà di fonoassorbenza dovute alle caratteristiche intrinseche di porosità dei materiali e alla particolare lavorazione, che offre una più estesa superficie di contatto con le onde incidenti favorendo la dissipazione di una maggiore quantità di energia sonora. La qualità acustica, elemento necessario ormai in ogni ambito per una migliore qualità di vita, diventa fondamentale in ambienti come teatri, cinema, biblioteche, studi di registrazione e televisivi, sale riunioni.

## GREEN THINKING

Lithos Design adotta tecniche di lavorazione che rispettano le persone e l'ambiente. La produzione, infatti, non prevede l'utilizzo di sostanze chimiche come coloranti o vernici. Inoltre, il sistema produttivo prevede il riciclaggio integrale delle acque utilizzate per ridurre al minimo l'impatto ambientale delle lavorazioni.

## ENERGY THINKING

La pietra naturale ha buone proprietà termiche. Un rivestimento in pietra contribuisce all'efficienza energetica di un edificio perché ottimizza la quantità di energia dedicata a riscaldamento e rinfrescamento.

## NATURAL THINKING

Lithos Design chose to work only with natural stone, and in particular with limestones, sandstones and marbles.

The company does not use agglomerates and manufactured or synthetic stones. Natural stones, especially when used as claddings, require easy care and maintain their natural beauty against time. The use of stone claddings contributes to the healthiness and safety of living spaces: natural stones are not inflammable, they do not get electrostatically charged, and do not encourage the development of bacteria and fungi. Besides, Lithos Design stone claddings have interesting sound absorbency features due to the intrinsic porosity of the materials used, and also to their peculiar 3D textures which provide a broader contact surface with the incidental wave, thus encouraging the dissipation of a higher amount of sound energy. The acoustic quality of any living space is by now essential for a better life quality, and it becomes vital in such settings as theatres, cinemas, libraries, recording and TV studios, meeting rooms.

## GREEN THINKING

Lithos Design processing techniques are respectful of people and of the environment. Indeed, the production does not require the use of chemicals such as colorants or varnishes. In addition, the manufacturing system provides for total wastewater recycling, minimizing its environmental impact.

## ENERGY THINKING

Natural stone has good thermal properties. A stone cladding contributes to the energy performance of a building, optimizing the quantity of energy used for heating and cooling.



LE PIETRE INCISE

## LE PIETRE INCISE

Geometrie in movimento, texture incantevoli e mutevoli al tempo stesso, giochi di luce ed effetti ottici per una collezione di rivestimenti in pietra capace di disegnare lo spazio e renderlo unico. Le Pietre Incise, prima collezione e icona del brand, raccoglie oggi 17 affascinanti modelli che esplorano le infinite potenzialità della materia litica, magistralmente interpretata da Lithos Design Primes attraverso lo sviluppo di un design che si integra alla

perfezione con il processo produttivo industriale. Per alcuni modelli di questa collezione vengono offerti anche due tipi di complementi, Curve Luce e Coni Luce, lastre di pietra curvata che ospitano al loro interno delle fonti luminose, aggiungendo profondità e dinamismo alla parete. La combinazione di ampie curve, eleganti decori e fasci di luce trasforma la superficie in una vera e propria espressione di design contemporaneo.

*Moving geometries, textures which are both charming and mutable, light games and optical effects for a collection of stone claddings with the ability to design space and make it unique. Le Pietre Incise, the brand's first and iconic line, now collects 17 fascinating models exploring the infinite potentialities of stone materials, which are interpreted in a masterly manner by Lithos Design Primes through the development of a*

*design study perfectly integrating with an industrial production process. For some models of this collection two types of complements are also available, namely Curve Luce and Coni Luce, curved stone slabs housing a light source within that add movement and depth to the wall. The combination of wide curves, elegant decorations and beams of light transforms the surface into a real contemporary design expression.*

# diamante

LE PIETRE INCISE

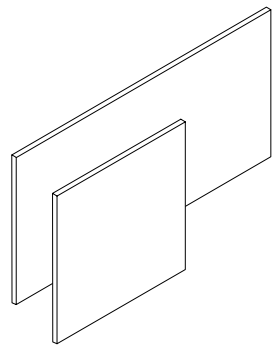

pietre incise  
60x60x2 cm  
120x60x2 cm



diamante, bianco narciso





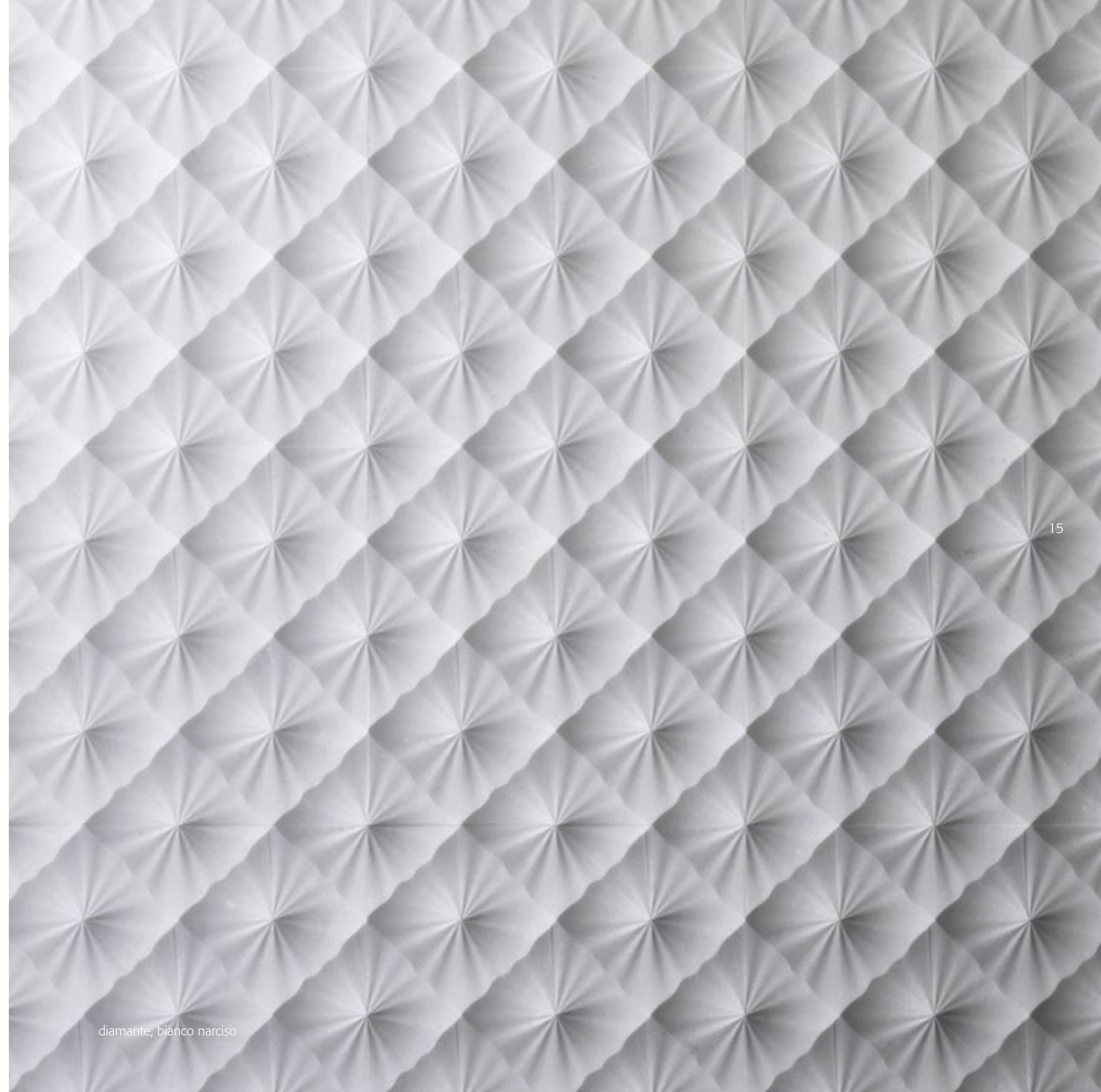

diamante, bianco narciso

# tropico

LE PIETRE INCISE

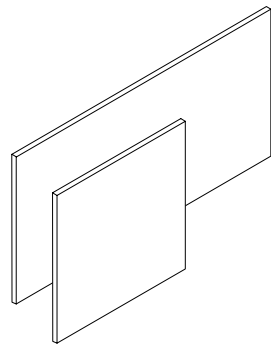

pietre incise  
60x60x2 cm  
120x60x2 cm



tropico, gris st pierre

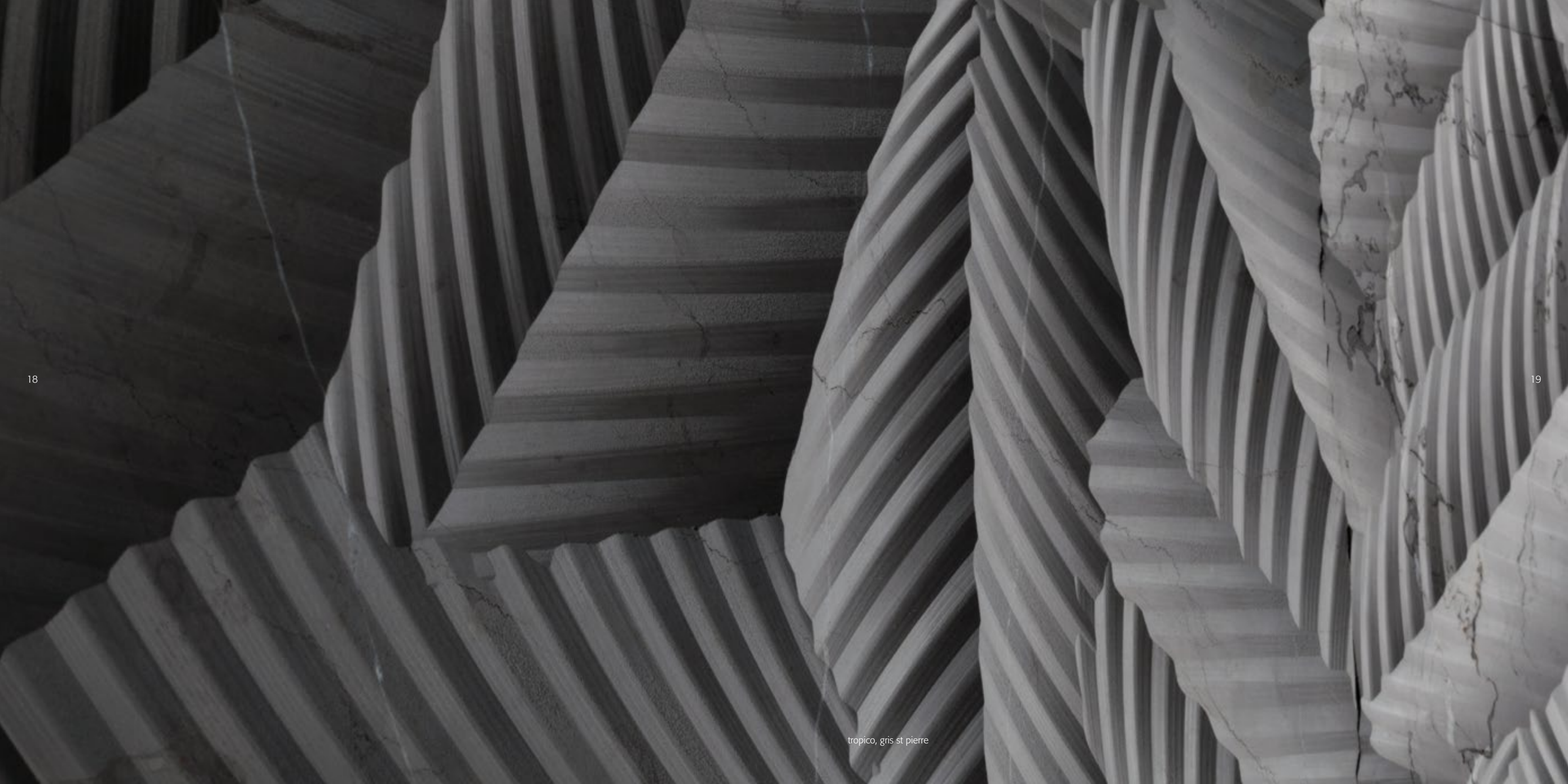



tropico, gris st pierre

# palma

LE PIETRE INCISE

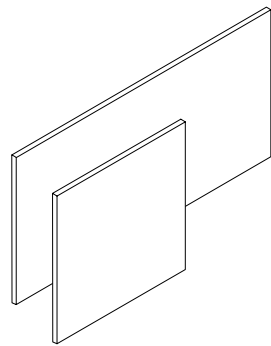

pietre incise  
60x60x2 cm  
120x60x2 cm



palma, silva oro





palma, silva oro



# sahara

LE PIETRE INCISE

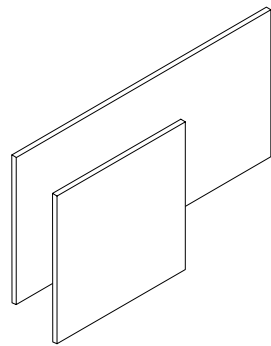

pietre incise  
60x60x2 cm  
120x60x2 cm



sahara, carrara ghiaccio





sahara, carrara ghiaccio

# seta

LE PIETRE INCISE

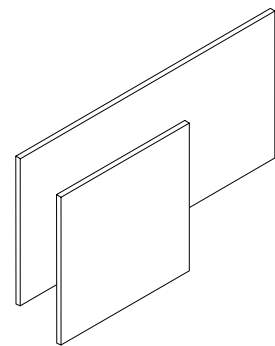

pietre incise  
60x60x2 cm  
120x60x2 cm

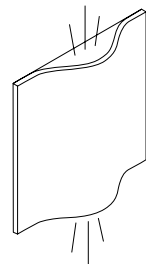

• pietre incise curve luce  
60x60x14 cm

• Only:  
bianco cotone, carrara ghiaccio, beige canapa,  
travertino latino, grigio tundra, pierre bleue



seta, beige canapa





seta, giallo dorato







seta, bianco cotone; seta curve luce, bianco cotone







seta, travertino latino; seta curve luce, travertino latino



# fondo

LE PIETRE INCISE

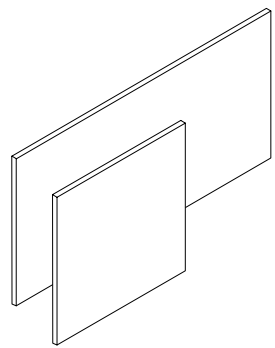

pietre incise  
60x60x2 cm  
120x60x2 cm

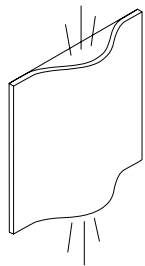

• pietre incise curve luce  
60x60x14 cm

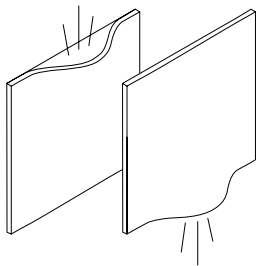

• pietre incise con luce  
60x60x14 cm

• Only:  
bianco cotone, carrara ghiaccio, beige canapa,  
travertino latino, grigio tundra, pierre bleue



fondo, ocra sabbia



fondo, ocra sabbia



fondo, ocra sabbia



fondo, beige tortora



fondo, beige tortora



fondo, ocre sabbia; fondo curve luce, ocre sabbia



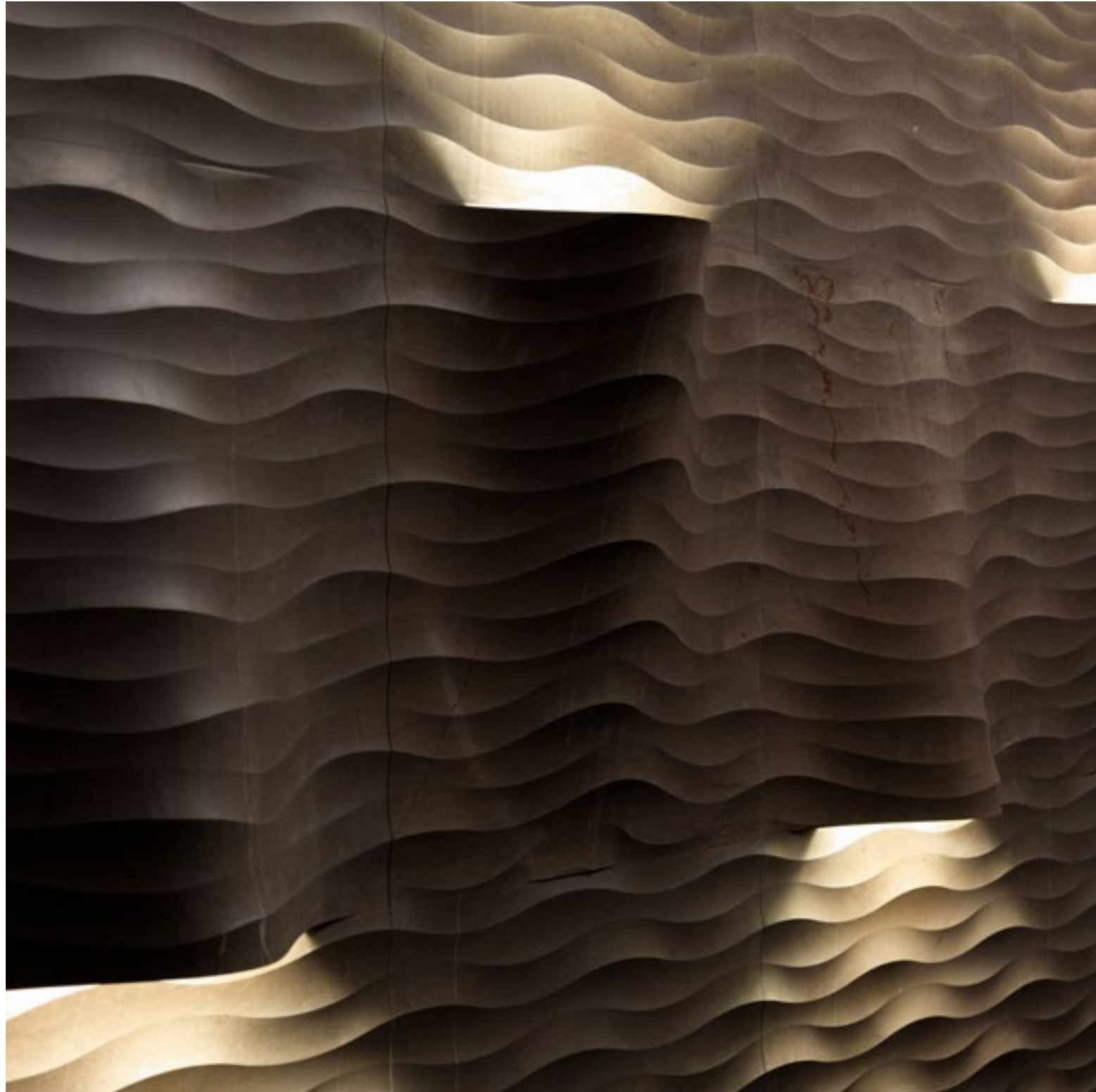

fondo, grigio tundra; fondo con luce, grigio tundra



# tratto

LE PIETRE INCISE

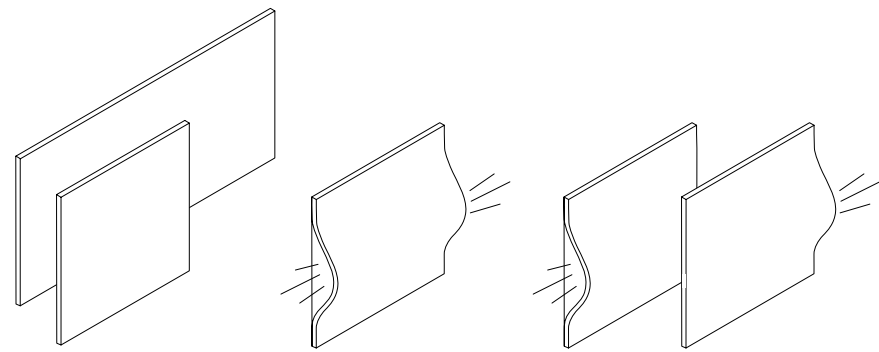

pietre incise  
60x60x2 cm  
120x60x2 cm

•pietre incise curve luce  
60x60x14 cm

•pietre incise coni luce  
60x60x14 cm

• Only:  
bianco cotone, carrara ghiaccio, beige canapa,  
travertino latino, grigio tundra, pierre bleue

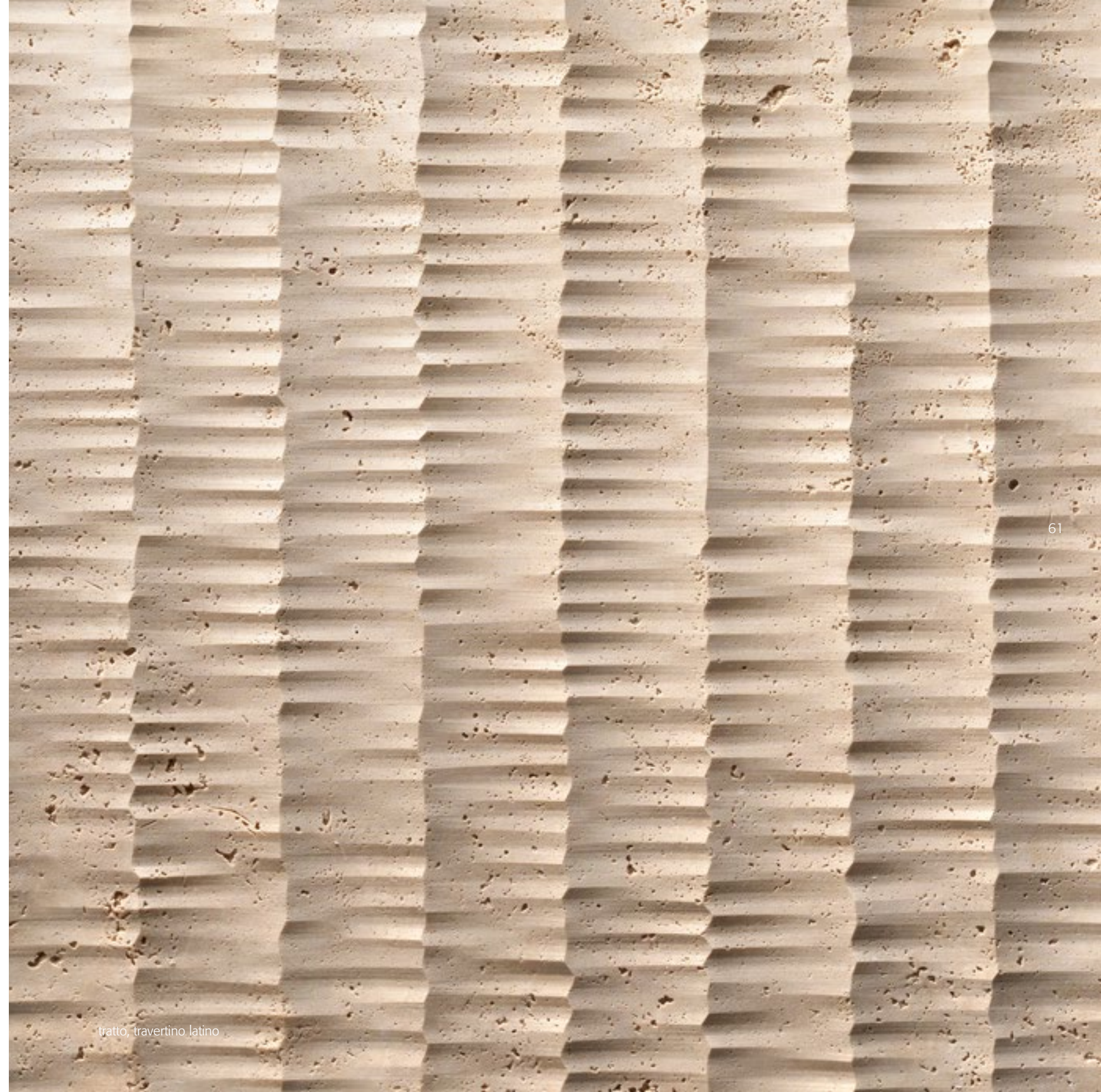

tratto, travertino latino



tratto, travertino latino





tratto, travertino latino

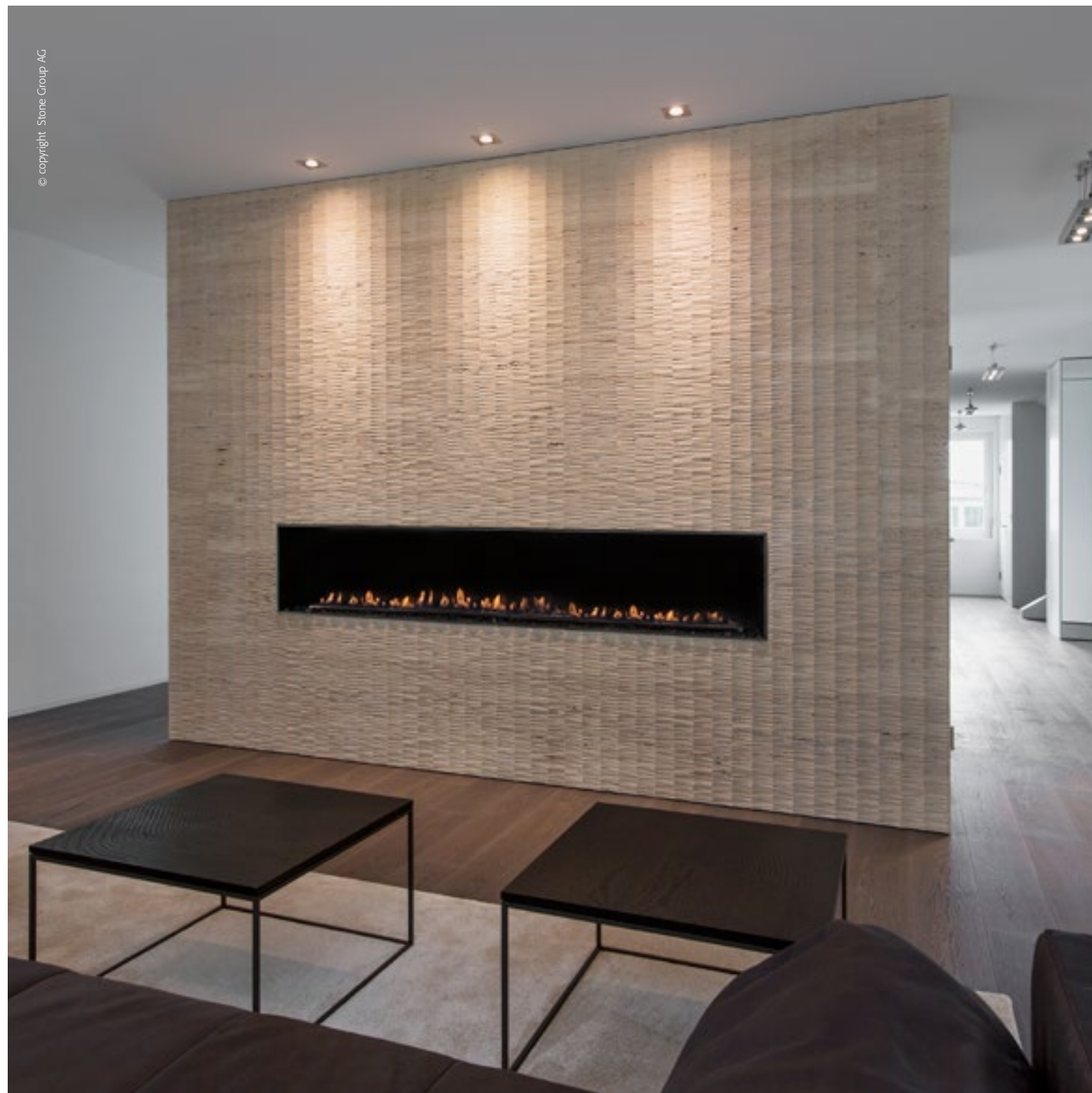



tratto, grigio tundra; tratto curve luce, grigio tundra





tratto, grigio tundra; tratto con luce, grigio tundra

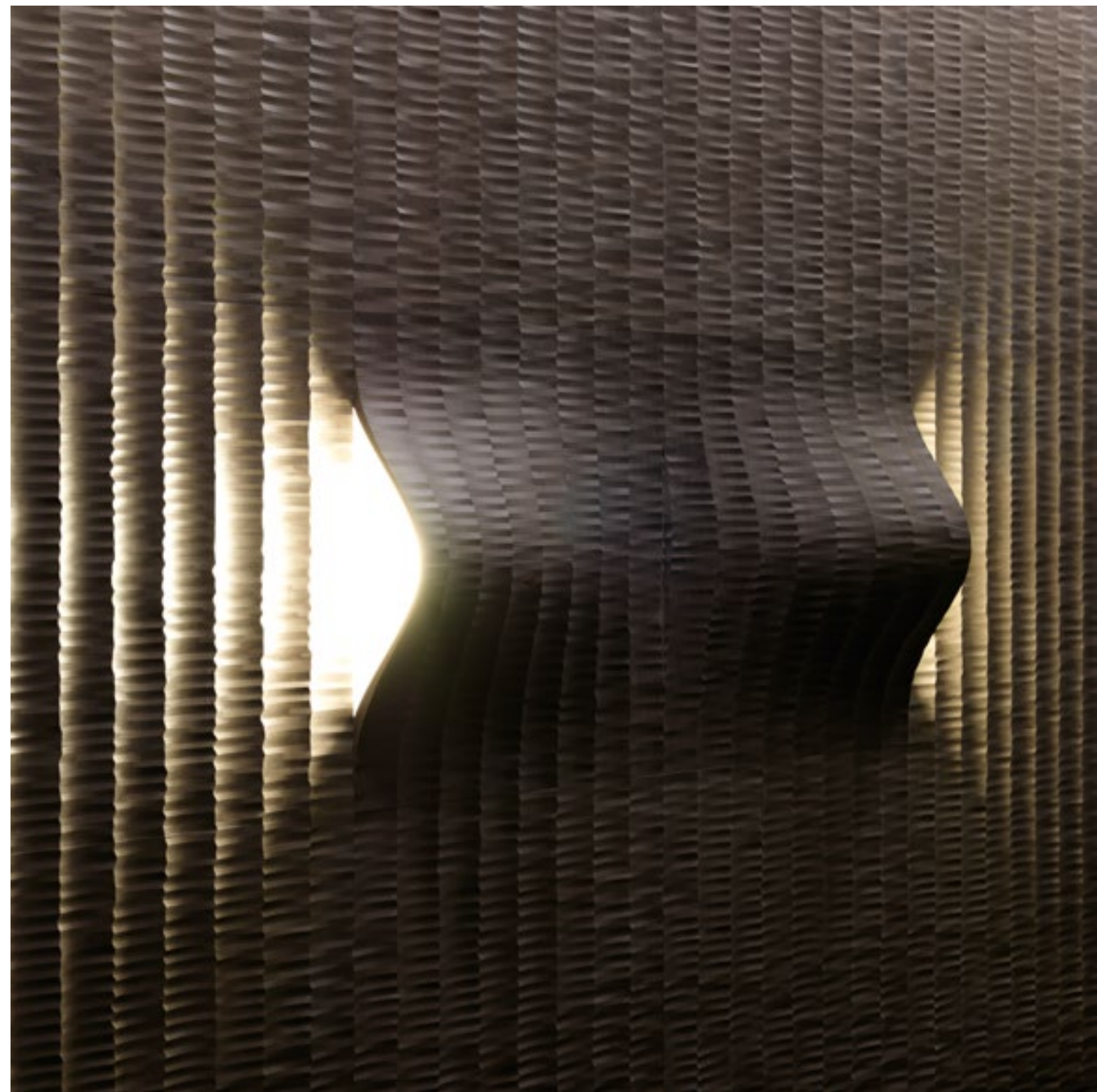

# quadro

LE PIETRE INCISE

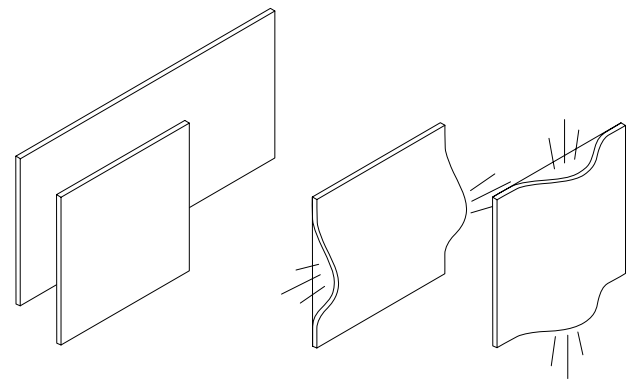

pietre incise  
60x60x2 cm  
120x60x2 cm

•pietre incise curve luce  
60x60x14 cm

• Only:  
bianco cotone, carrara ghiaccio, beige canapa,  
travertino latino, grigio tundra, pierre bleue

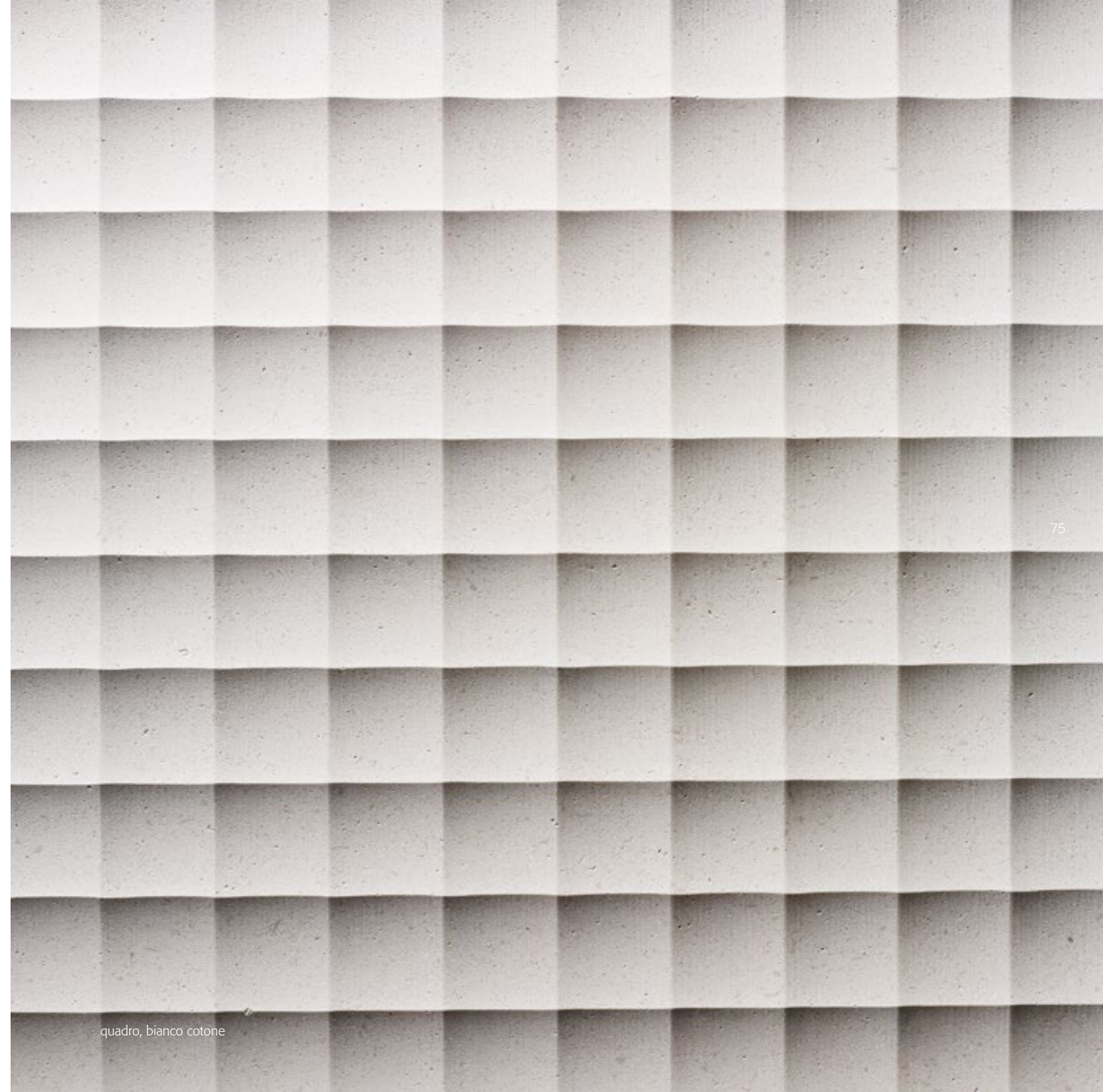

quadro, bianco cotone



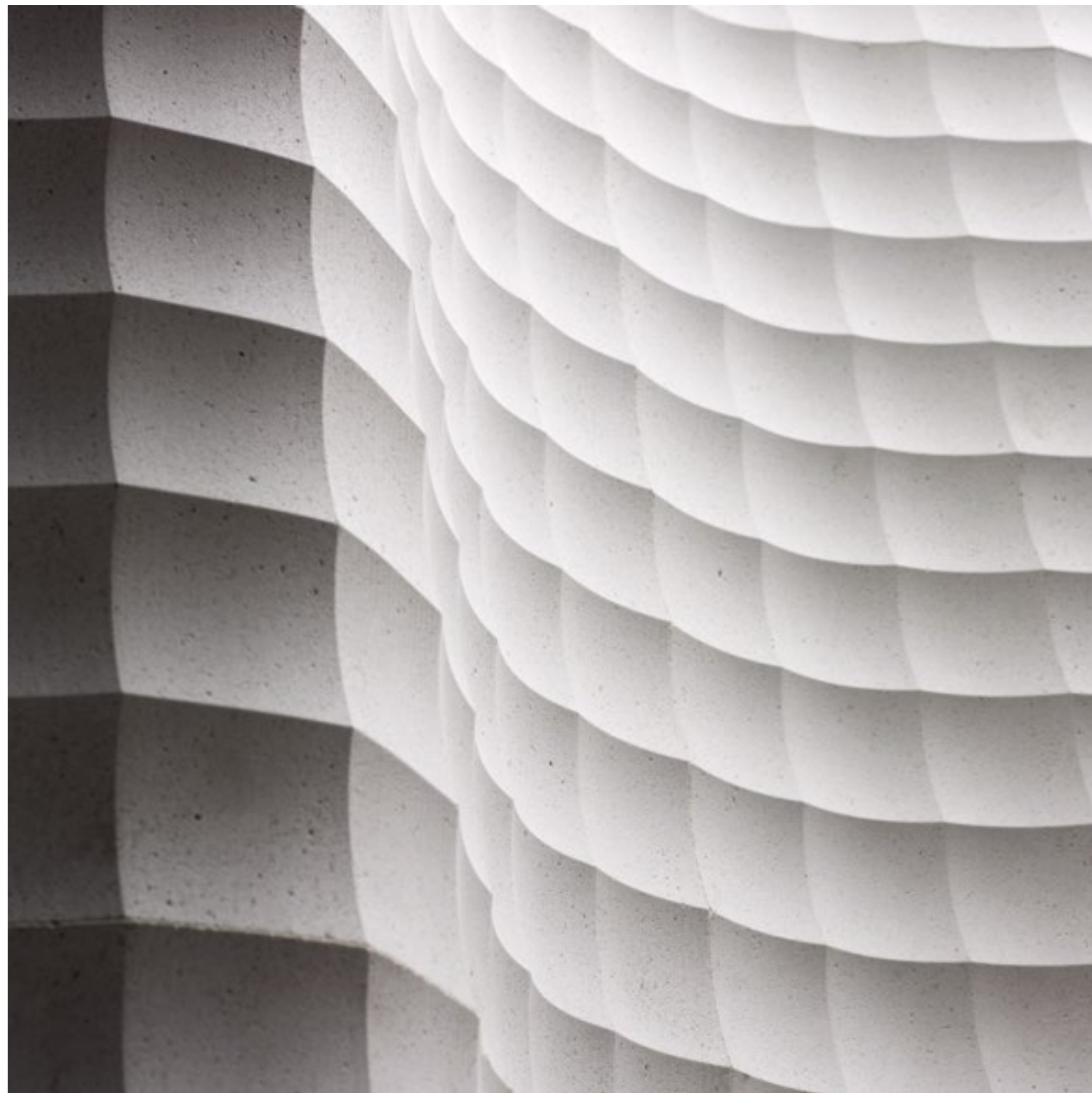

quadro, bianco cotone; quadro curve luce, bianco cotone

# favo

LE PIETRE INCISE

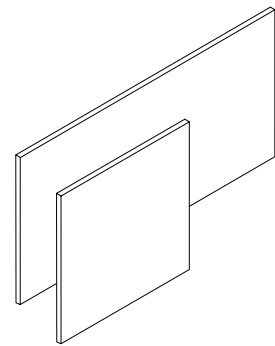

pietre incise  
60x60x2 cm  
120x60x2 cm

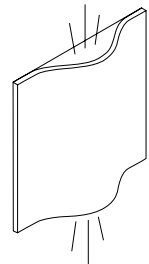

• pietre incise curve luce  
60x60x14 cm

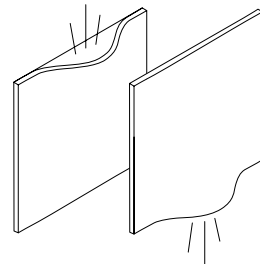

• pietre incise con luce  
60x60x14 cm

• Only:  
bianco cotone, carrara ghiaccio, beige canapa,  
travertino latino, grigio tundra, pierre bleue

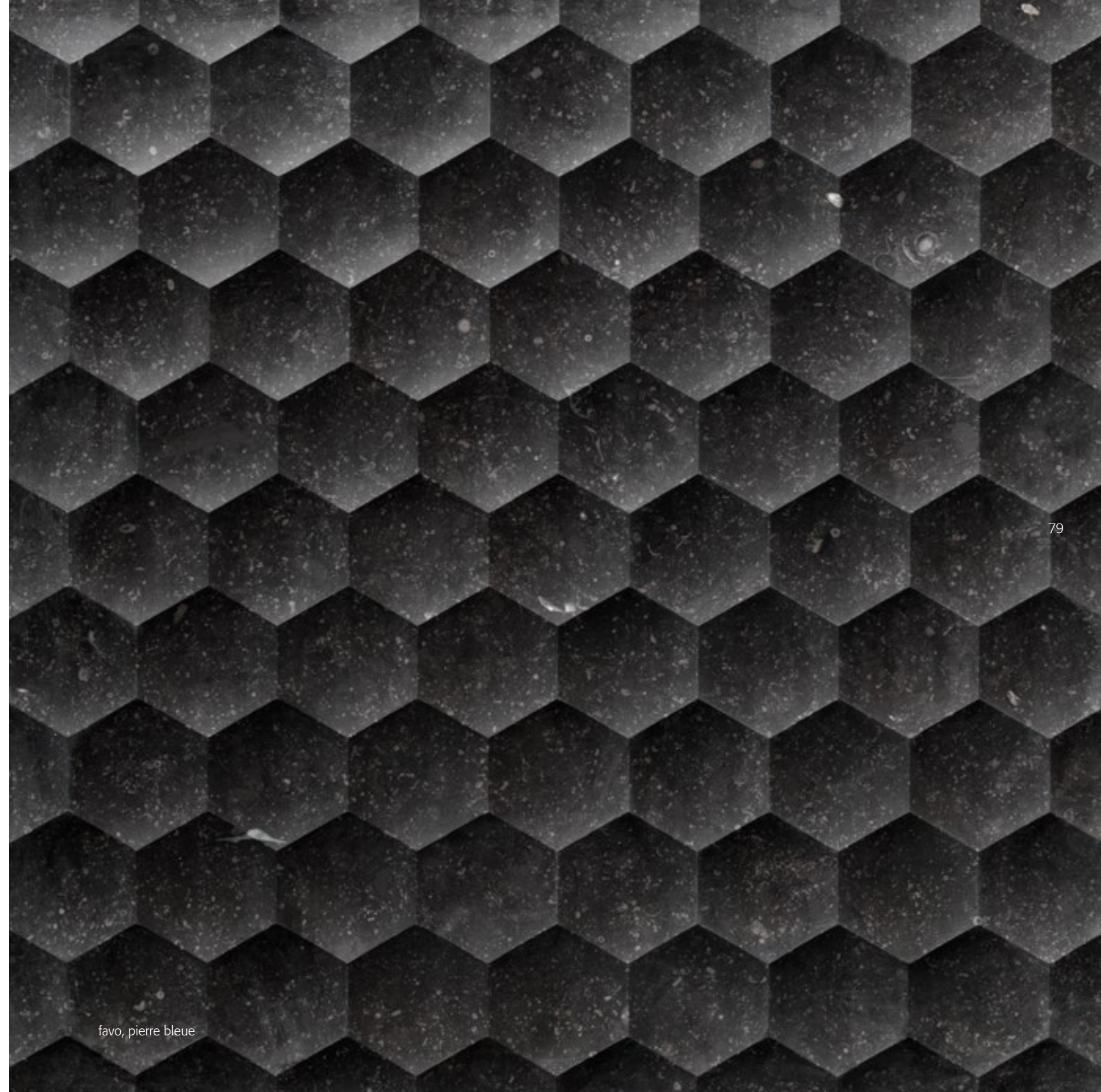

favo, pierre bleue



favo, pierre bleue; favo curve luce, pierre bleue

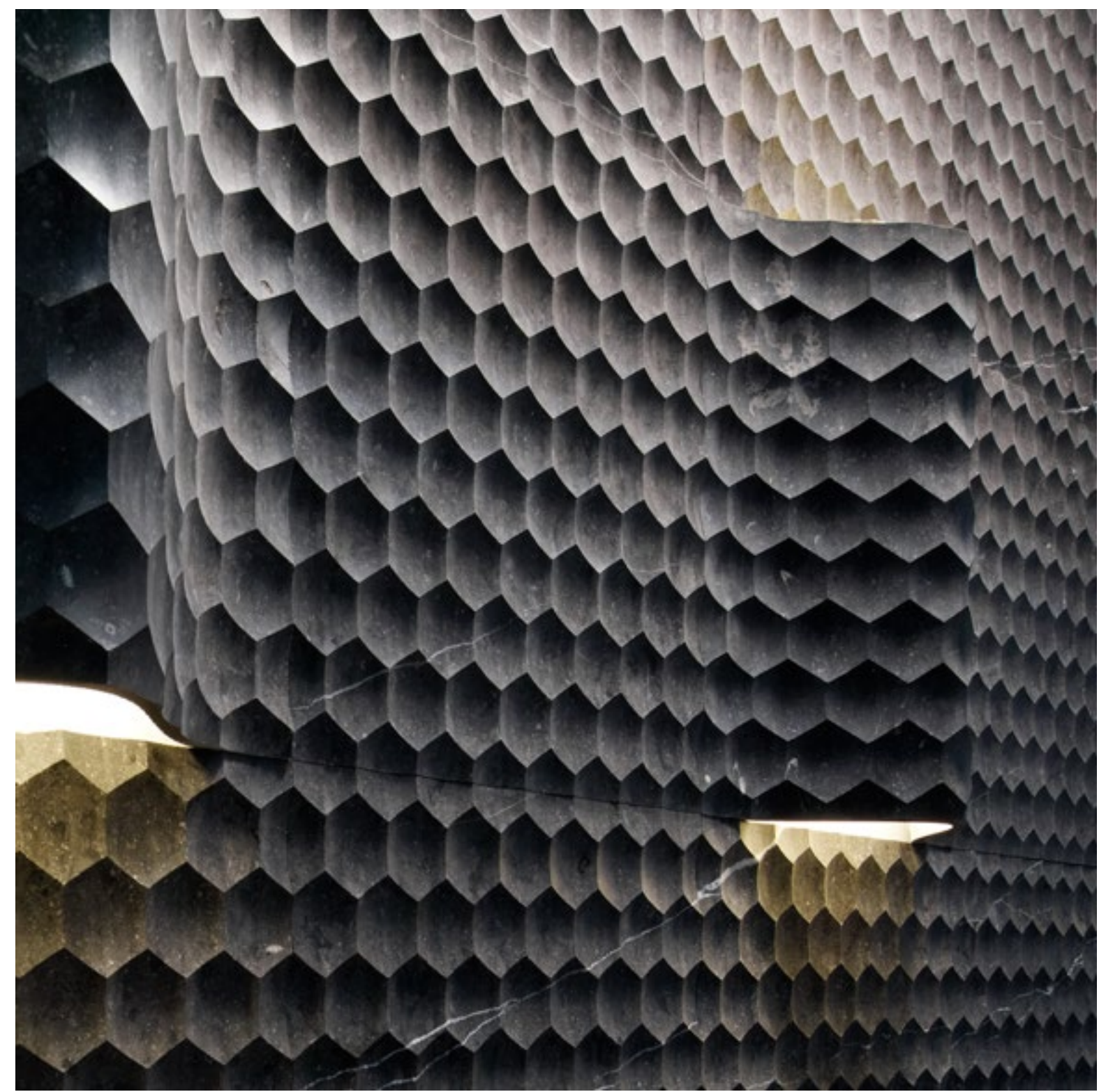

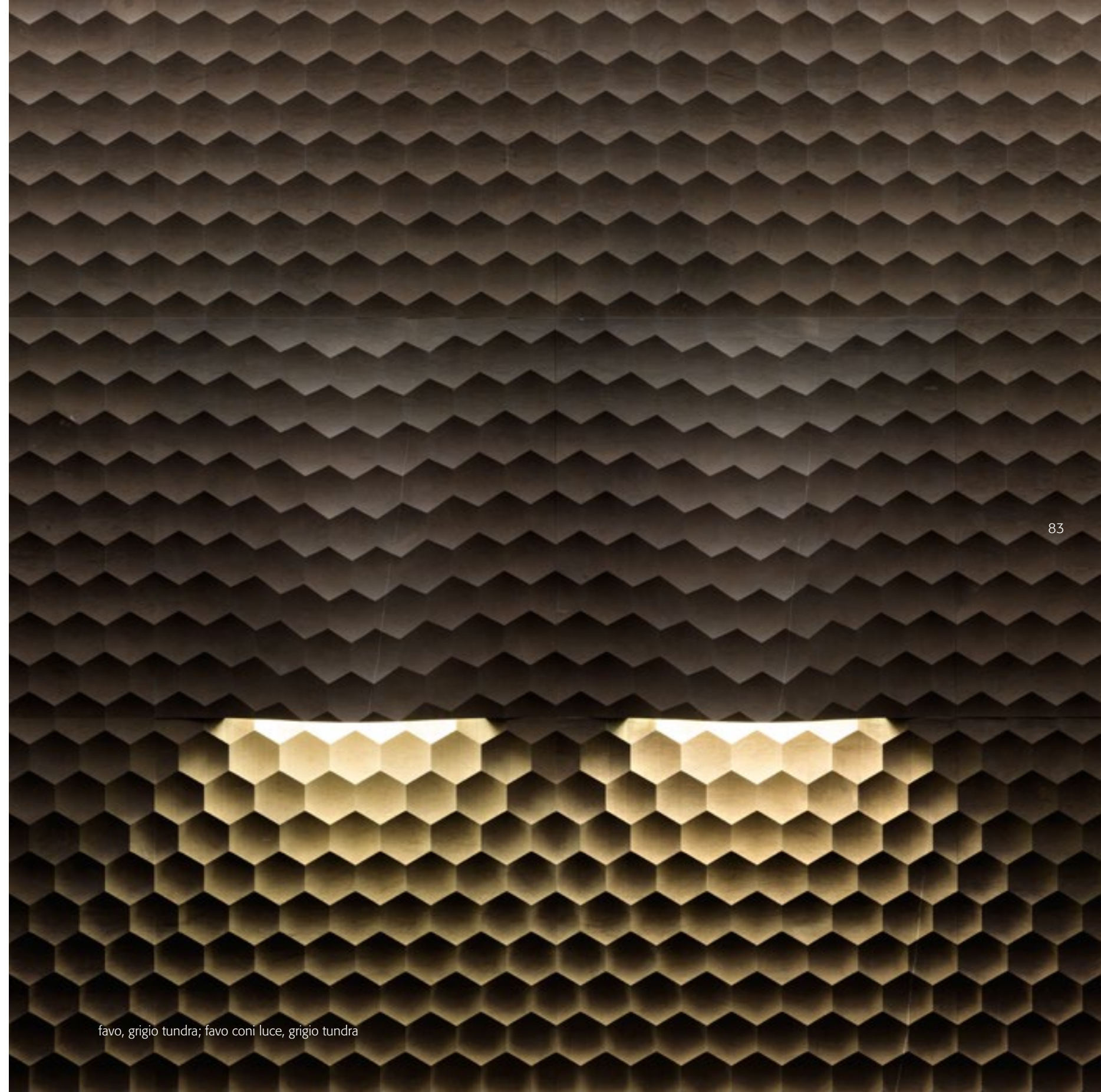
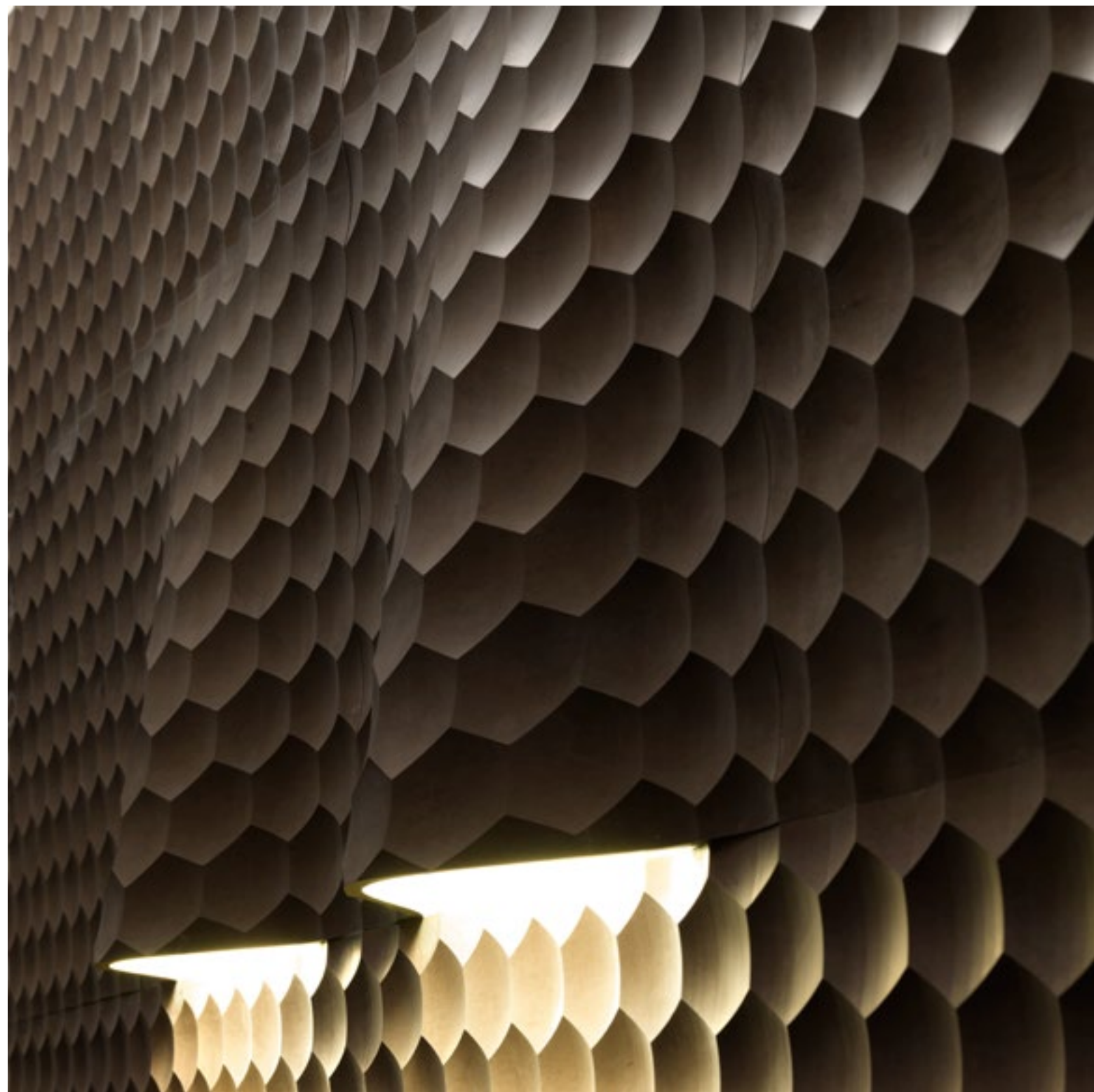

favo, grigio tundra; favo con luce, grigio tundra



# cubo

LE PIETRE INCISE

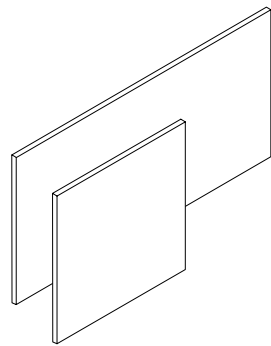

pietre incise  
60x60x2 cm  
120x60x2 cm



cubo, ocra sabbia





cubo, ocra sabbia



# lembo

LE PIETRE INCISE

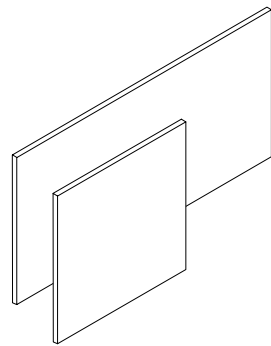

pietre incise  
60x60x2 cm  
120x60x2 cm



lembo, bianco narciso



lembo, bianco cotone

# terra

LE PIETRE INCISE

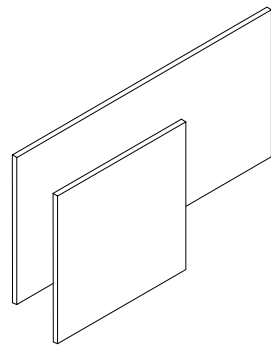

pietre incise  
60x60x2 cm  
120x60x2 cm



terra, grigio cenere



terra, grigio cenere



# virgola

LE PIETRE INCISE

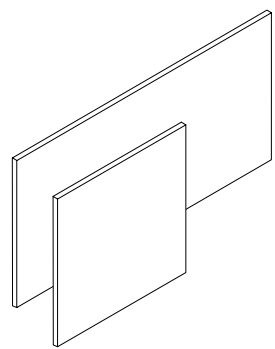

pietre incise  
60x60x2 cm  
120x60x2 cm

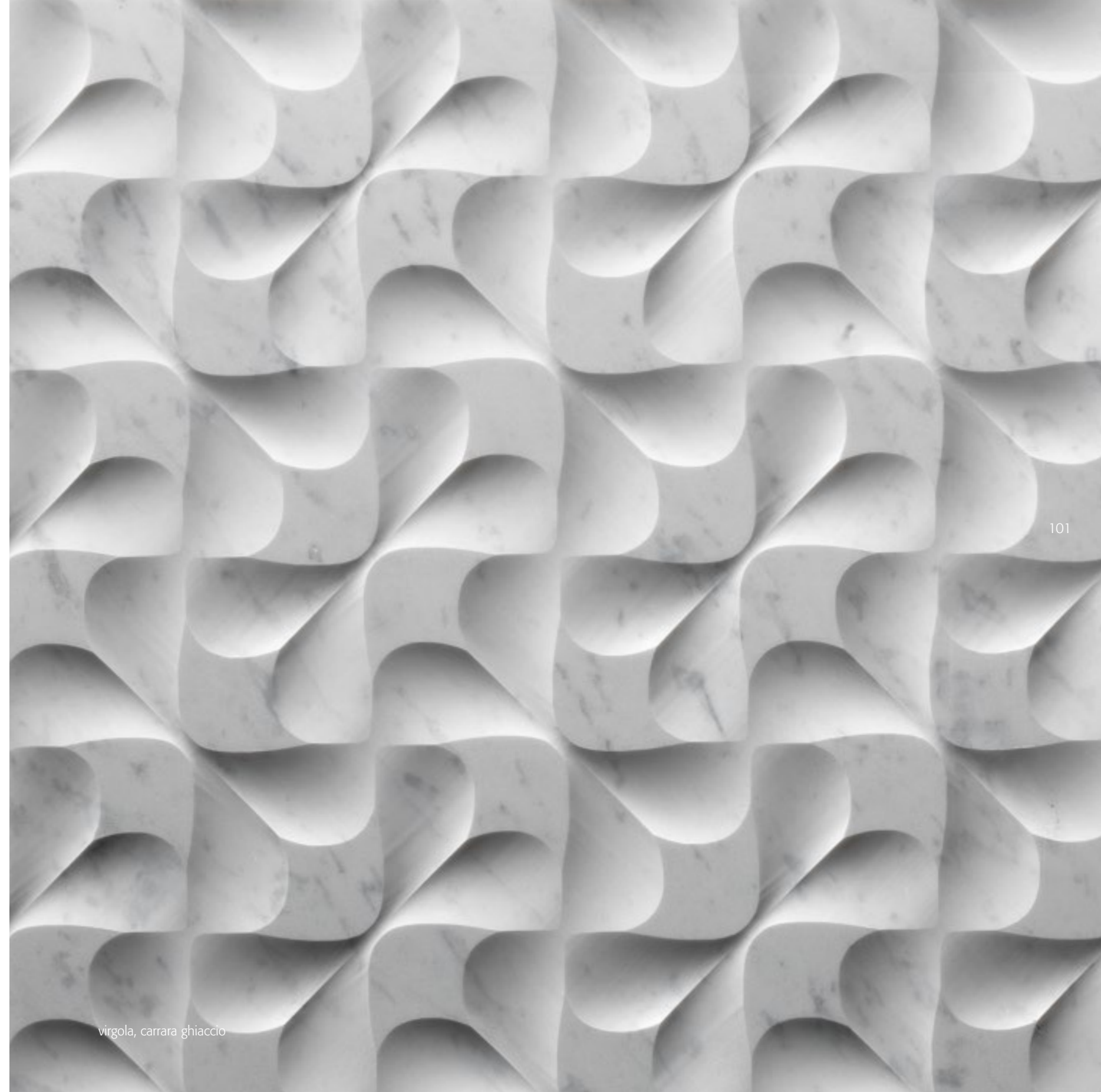

virgola, carrara ghiaccio



virgola, grigio cenere

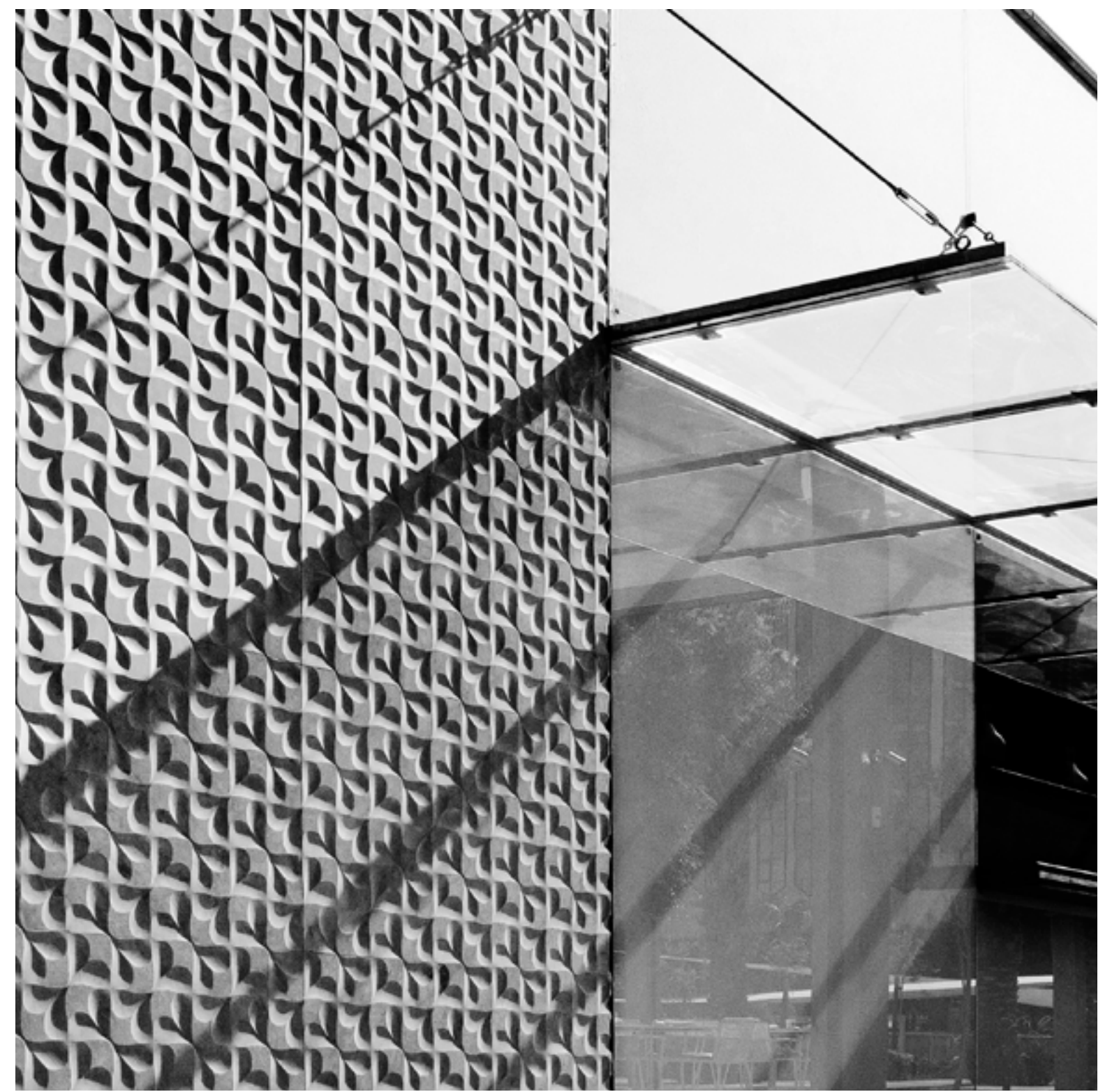

# giza

LE PIETRE INCISE

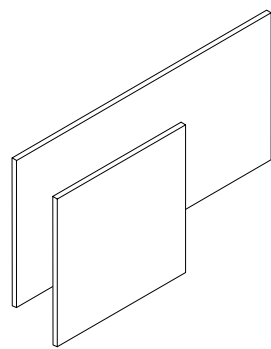

pietre incise  
60x60x2 cm  
120x60x2 cm

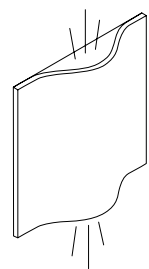

• pietre incise curve luce  
60x60x14 cm



• Only:  
bianco cotone, carrara ghiaccio, beige canapa,  
grigio tundra, pierre bleue



giza, grigio cenere



giza, pierre bleue; giza curve luce, pierre bleue





# doge

LE PIETRE INCISE

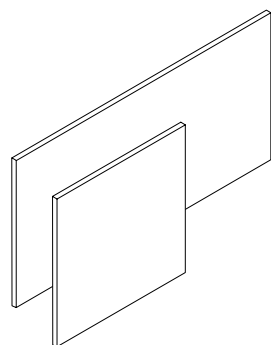

pietre incise  
60x60x2 cm  
120x60x2 cm



doge, rosa dolomiti

110

# gemma

LE PIETRE INCISE

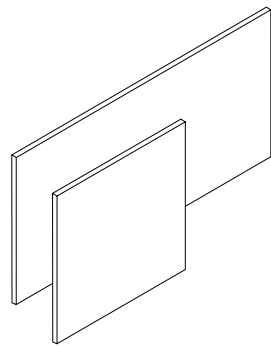

pietre incise  
60x60x2 cm  
120x60x2 cm



111

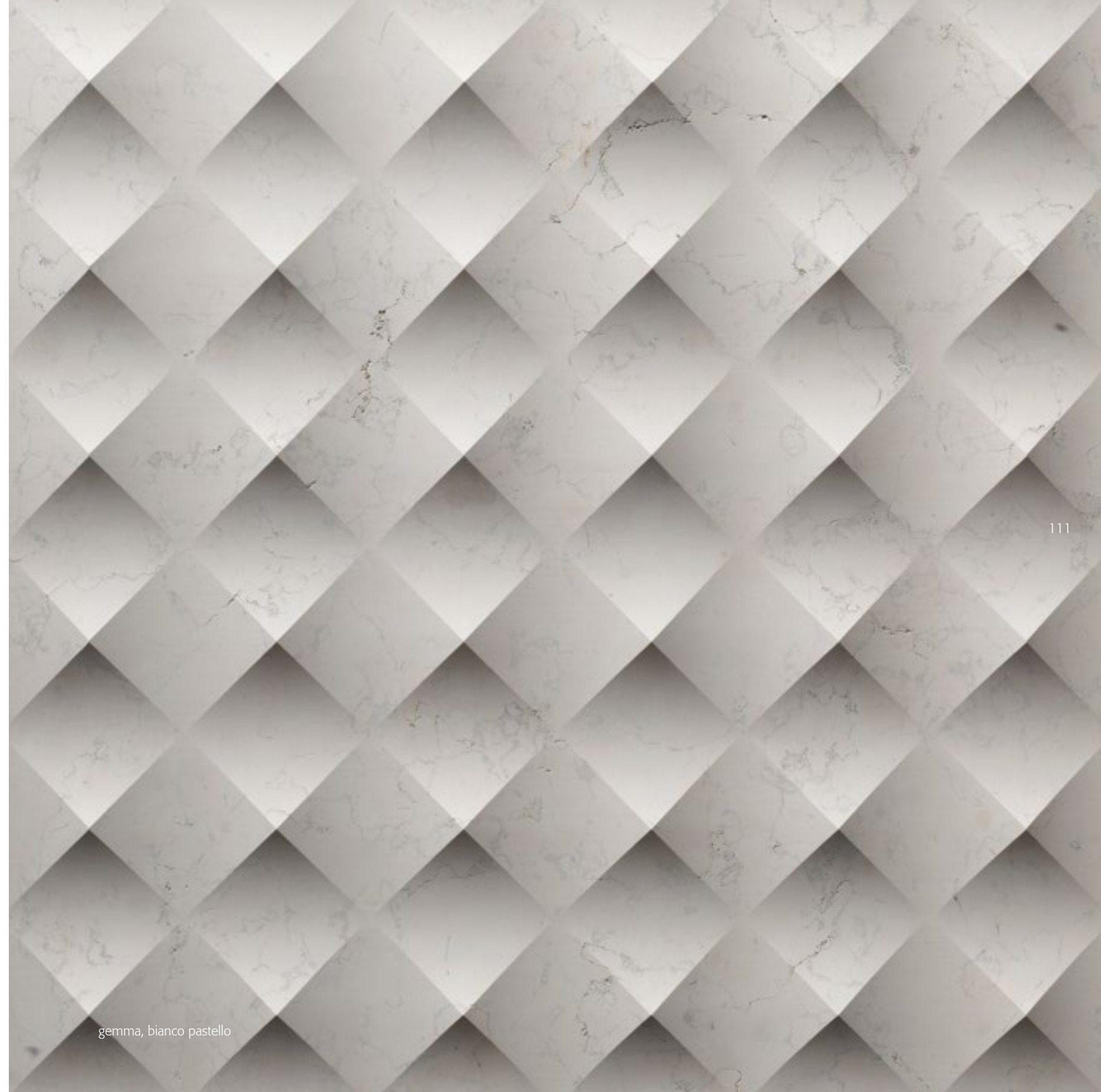

gemma, bianco pastello

# prisma

LE PIETRE INCISE

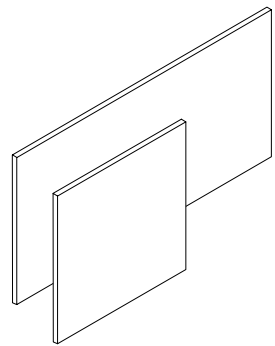

pietre incise  
60x60x2 cm  
120x60x2 cm



prisma, grigio tundra



LE PIETRE INCISE PALLADIO

# LE PIETRE INCISE PALLADIO

Omaggio al genio di Palladio. La collezione di rivestimenti Le Pietre Incise Palladio nasce da un approfondito studio di Raffaello Galiotto - in collaborazione con il Centro Internazionale di Studi di Architettura Andrea Palladio - delle linee architettoniche dell'Architetto vicentino, dalle quali emerge un profilo geometrico ricorrente che è diventato il presupposto dei modelli di questa collezione. Le Pietre Incise Palladio è una prestigiosa collezione di rivestimenti in pietra che fonde echi del passato e motivi contemporanei in un dialogo continuo tra armonia delle linee,

forte tridimensionalità e bellezza materica della pietra esaltata da una magistrale lavorazione. Riuscite performances di design in tributo al Palladio che affermava come "la bellezza risulta proprio dalla corrispondenza del tutto alle parti, delle parti fra loro, e di quelle al tutto". Con questi 5 modelli Lithos Design è riuscita nell'intento di elaborare senza snaturare l'essenza della classicità e dei suoi fondamentali, ha lavorato con superfici, luci e ombre riproponendo lo stile classico con un linguaggio contemporaneo.

*A tribute to Palladio's genius. The claddings collection named Le Pietre Incise Palladio is the result of an in-depth study made by Raffaello Galiotto on the architectural lines by Andrea Palladio – a study made in collaboration with the Centro Internazionale di Studi di Architettura Andrea Palladio. This work highlighted a recurring geometric profile which became the basic element of the models composing this collection. Le Pietre Incise Palladio is a prestigious line of claddings which merges echoes of the past with contemporary motifs in a constant dialogue between harmonious*

*lines, a strong 3D nature and the textured appeal of stone enhanced by the processing: successful design performances in tribute to Palladio, who stated that beauty results exactly from "the relation between everything and the parts, between the parts themselves, and from them to everything". With these 5 models Lithos Design achieved its goal of elaborating without uprooting the essence of the classic appeal and its fundamental traits, working with surfaces, lights and shadows, and revamping the classic style with a contemporary approach.*

# palladio RV2

LE PIETRE INCISE PALLADIO

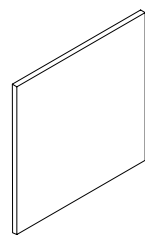

pietre incise palladio  
60x60x4 cm



palladio RV2, carrara ghiaccio





palladio RV2, bianco cotone





palladio RV2, bianco cotone



# palladio RV6

LE PIETRE INCISE PALLADIO

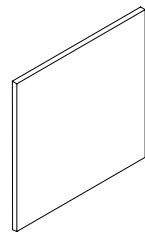

pietre incise palladio  
60x60x5 cm



palladio RV6, rosso pastello



palladio RV6, rosso pastello



palladio RV6, rosso pastello



# palladio RV3

LE PIETRE INCISE PALLADIO

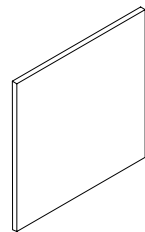

pietre incise palladio  
60x60x3 cm

bianco cotone   carrara ghiaccio   pierre bleue   nero marquinia

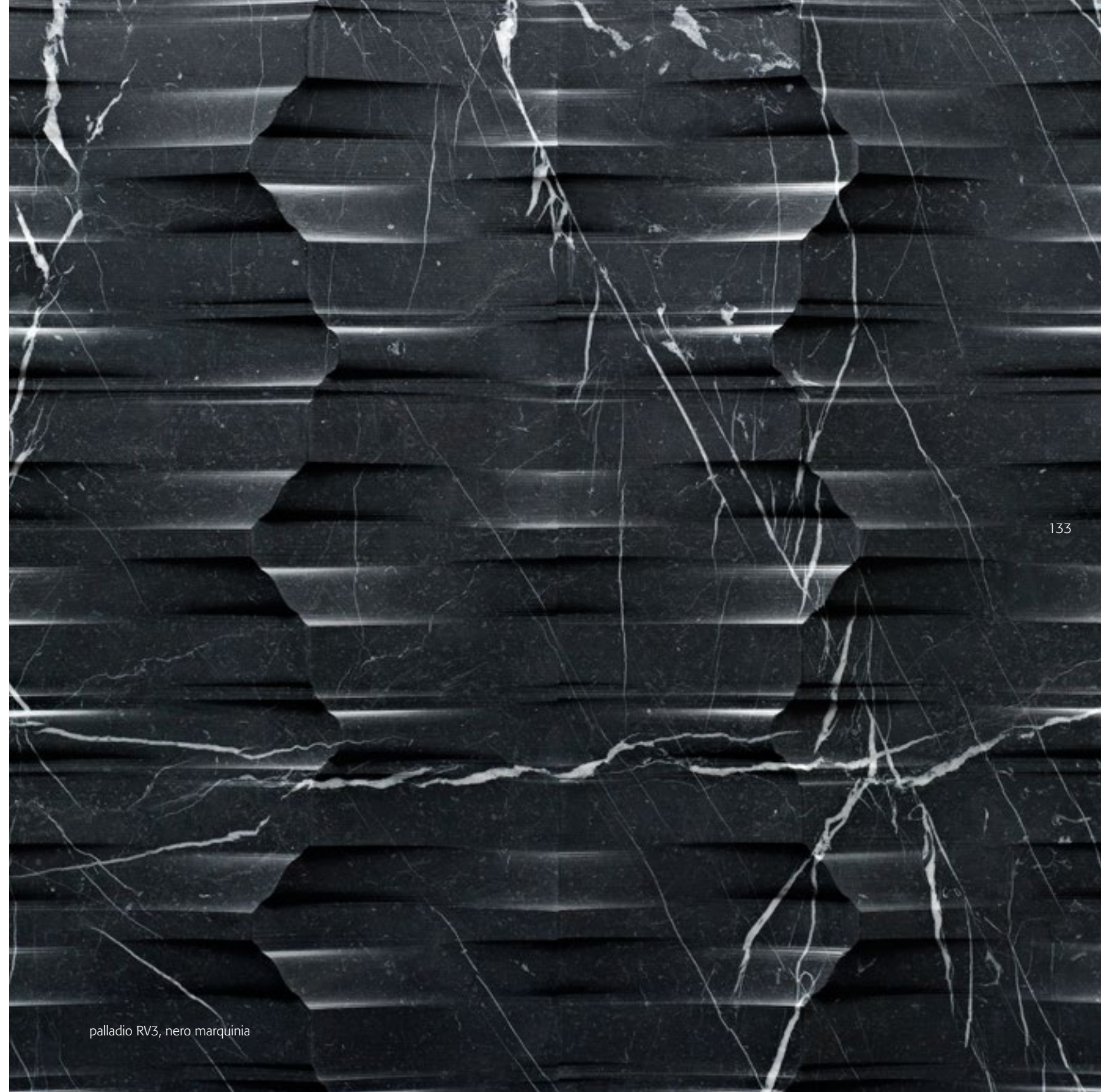
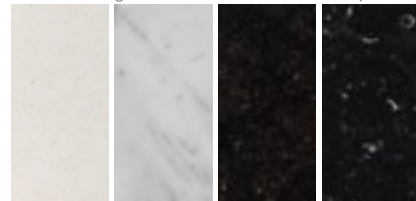

palladio RV3, nero marquinia



palladio RV3, nero marquina



# palladio RV1

LE PIETRE INCISE PALLADIO

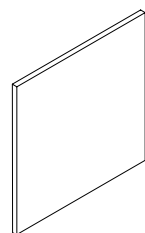

pietre incise palladio  
60x60x4 cm

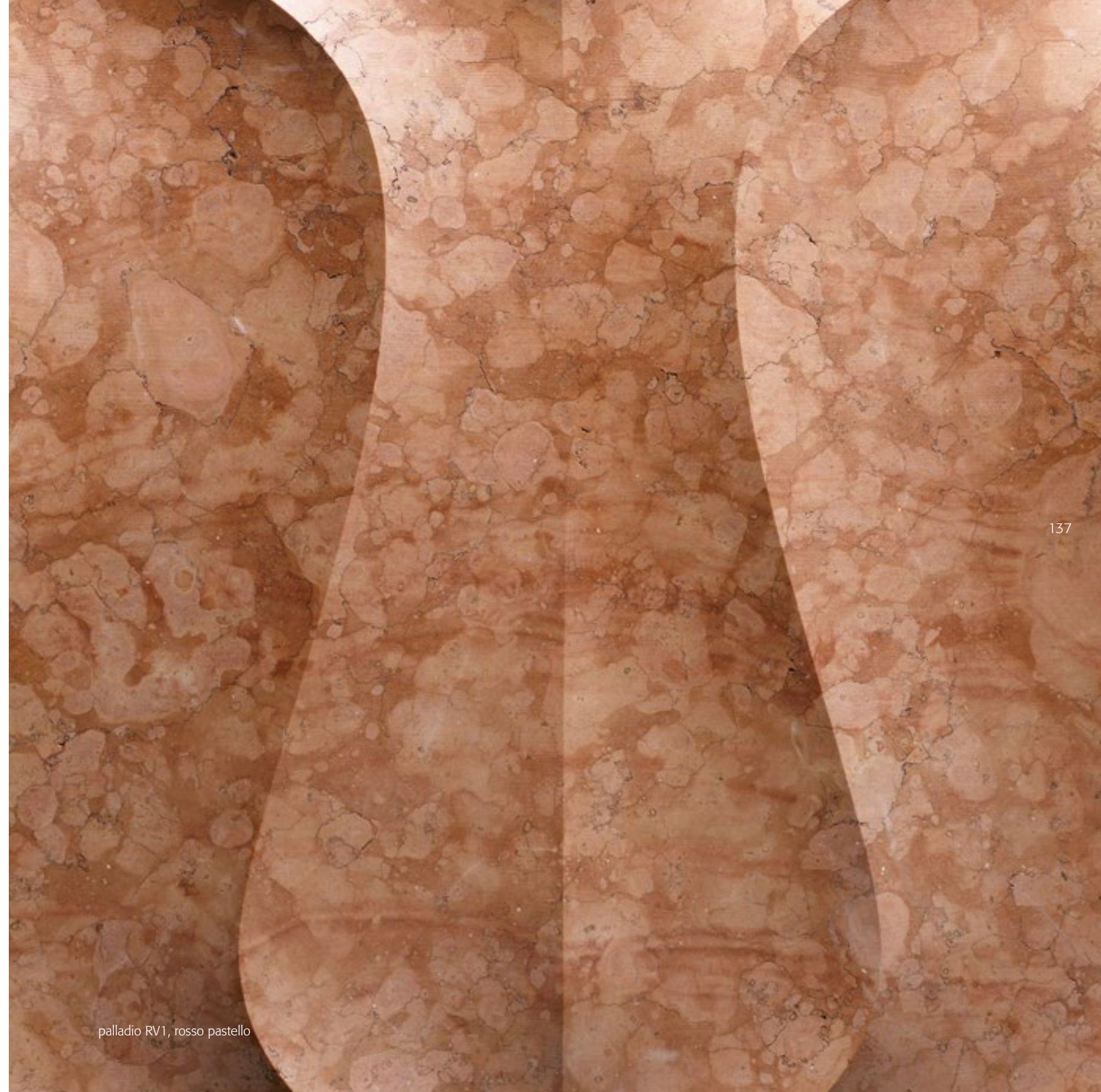

palladio RV1, rosso pastello

# palladio RV7

LE PIETRE INCISE PALLADIO

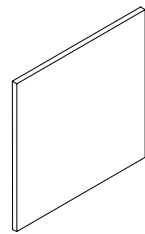

pietre incise palladio  
60x60x6 cm

bianco cotone    ocra sabbia    giallo dorato



palladio RV7, ocra sabbia





NUANCE

# NUANCE

Strutture articolate di incisioni che lavorano su piani, inclinazioni e profondità diverse. Le superfici di questi rivestimenti, magistralmente lavorate, si accendono di nuance tonali ideali creando emozionanti e raffinatissime atmosfere. La collezione Nuance nasce da un approfondito studio del designer Raffaello Galiotto sulle potenzialità espressive di alcuni materiali lapidei caratterizzati da omogeneità tonale e materica, volto a esplorare le possibili modalità per esaltarne le proprietà chiaroscurali attraverso il design. Studiando le proprietà di riflessione della luce in rapporto alle pietre selezionate e abbinando una capacità di lavo-

razione che sfida le possibilità delle più moderne tecnologie esistenti, la nostra expertise ha dato vita a 6 diversi e sorprendenti modelli in cui la superficie guadagna più che una terza dimensione. Differenti spessori, livelli, tagli e forte sensorialità: con queste texture la luce si rifrange sul materiale decorato in un gioco intricato di contrasti e si scompone in una molteplicità di piani esprimendo infinite variazioni chiaroscurali in stupefacenti gradazioni ton sur ton. Una collezione unica, che sovverte l'idea tradizionale del rivestimento proponendo un equilibrio estetico perfetto per scelte decorative, sfumature tonali ed effetto tattile.

*Complex engraving patterns working on several planes, inclines and depths. The surfaces of these wall coverings, so masterfully processed, light up with ideal tone nuances creating exciting and highly refined atmospheres. The Nuance collection is the result of an in-depth study by designer Raffaello Galiotto as to the expressive potential of some stone materials characterized by an homogeneity of colour and texture, exploring how to enhance their chiaroscuro qualities through design. By studying the light reflection properties of the selected stones and teaming these with processing skills that*

*put to the test the possibilities of the latest modern technologies, our expertise gave life to 6 different and surprising models, allowing the surface to gain more than a third dimension. Different thicknesses, levels, cuts and a strong sensory texture: in these tiles, light is refracted on the decorated material in an intricate game of contrasts, and splits into a multitude of planes, expressing endless chiaroscuro variations in a spectacular scale of shades. A unique collection that subverts the traditional idea of coverings, proposing a perfect styling balance of decorative choices, tone shades and tactile effect.*

144

# tartan

NUANCE

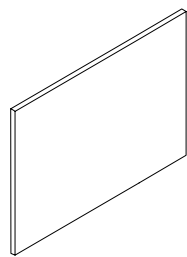

nuance  
80x40x2 cm

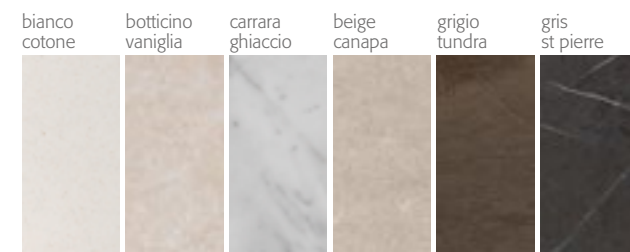

145

tartan, gris st pierre



tartan, gris st pierre



150

# vello

NUANCE

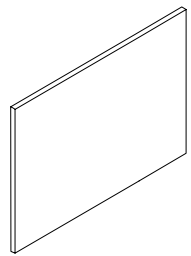

nuance  
80x40x2 cm

bianco  
cotone

botticino  
vaniglia

carrara  
ghiaccio

beige  
canapa

grigio  
tundra



151

vello, beige canapa

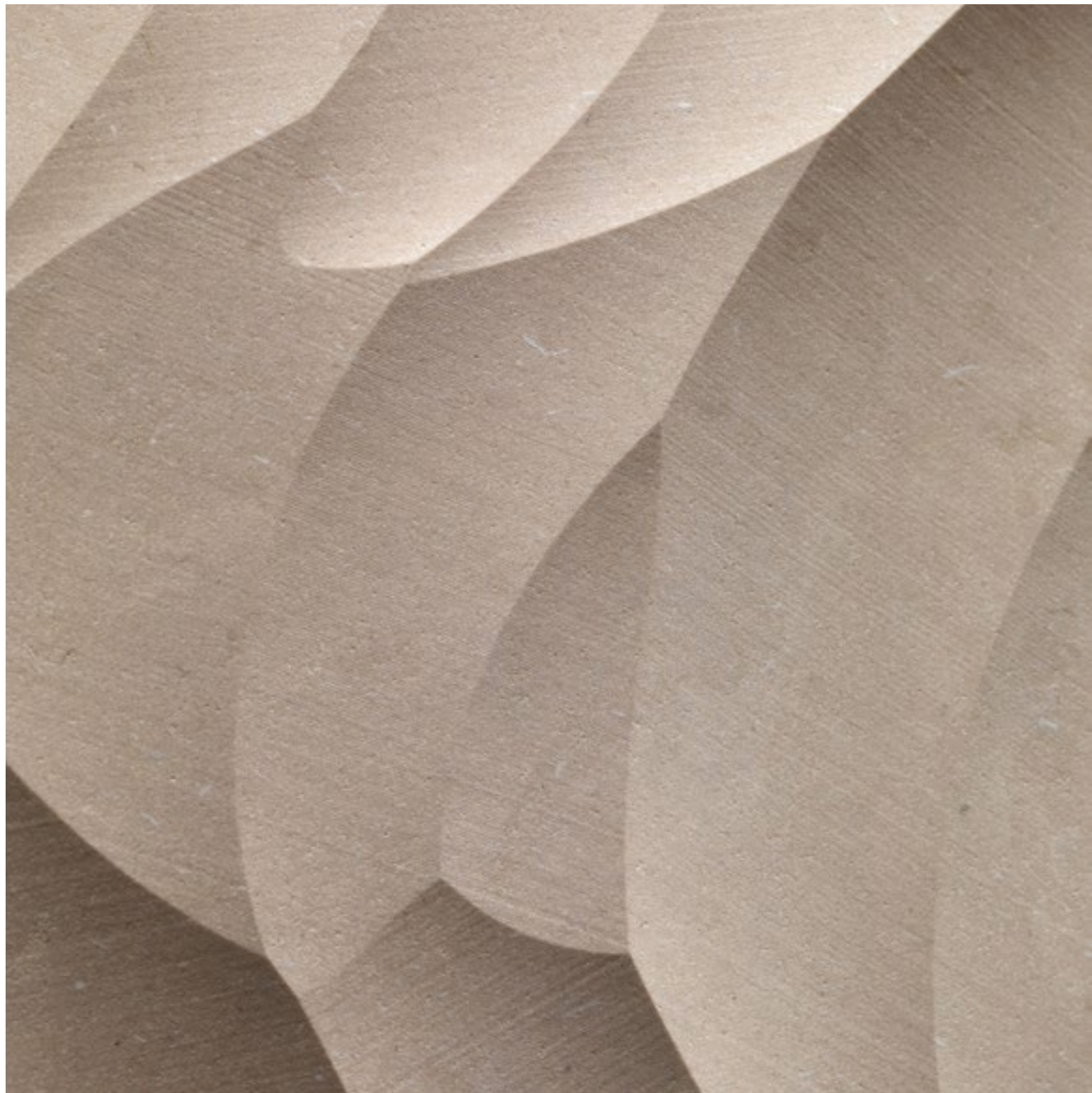

vello, beige canapa





# risma

NUANCE

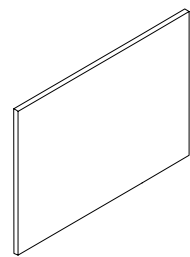

nuance  
80x40x2 cm



risma, carrara ghiaccio



risma, carrara ghiaccio



162

# vena

NUANCE

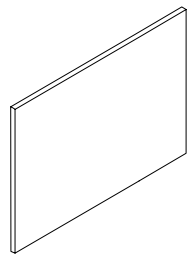

nuance  
80x40x2 cm

bianco  
cotone

botticino  
vaniglia

carrara  
ghiaccio

beige  
canapa

grigio  
tundra



163

vena, grigio tundra

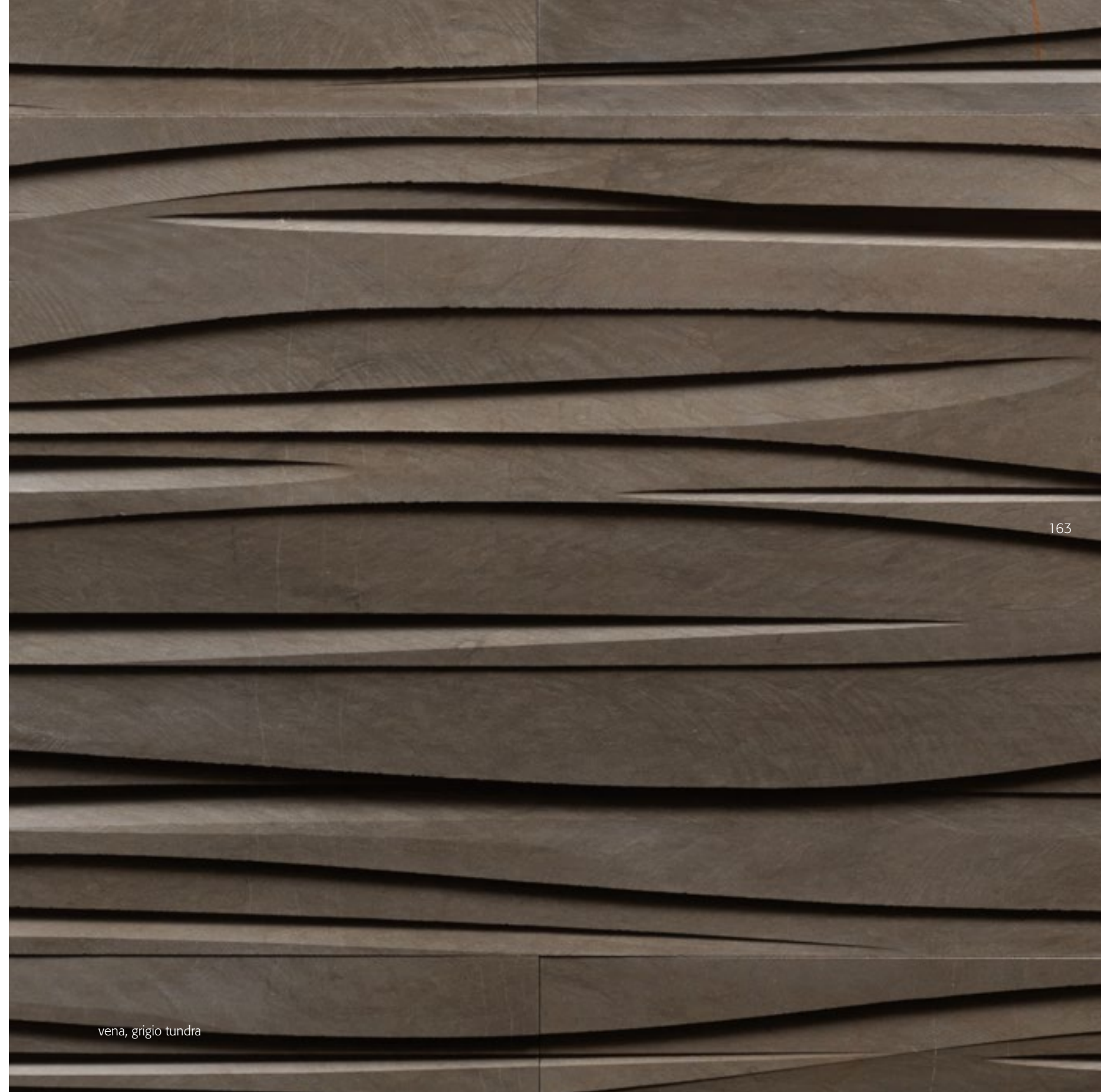

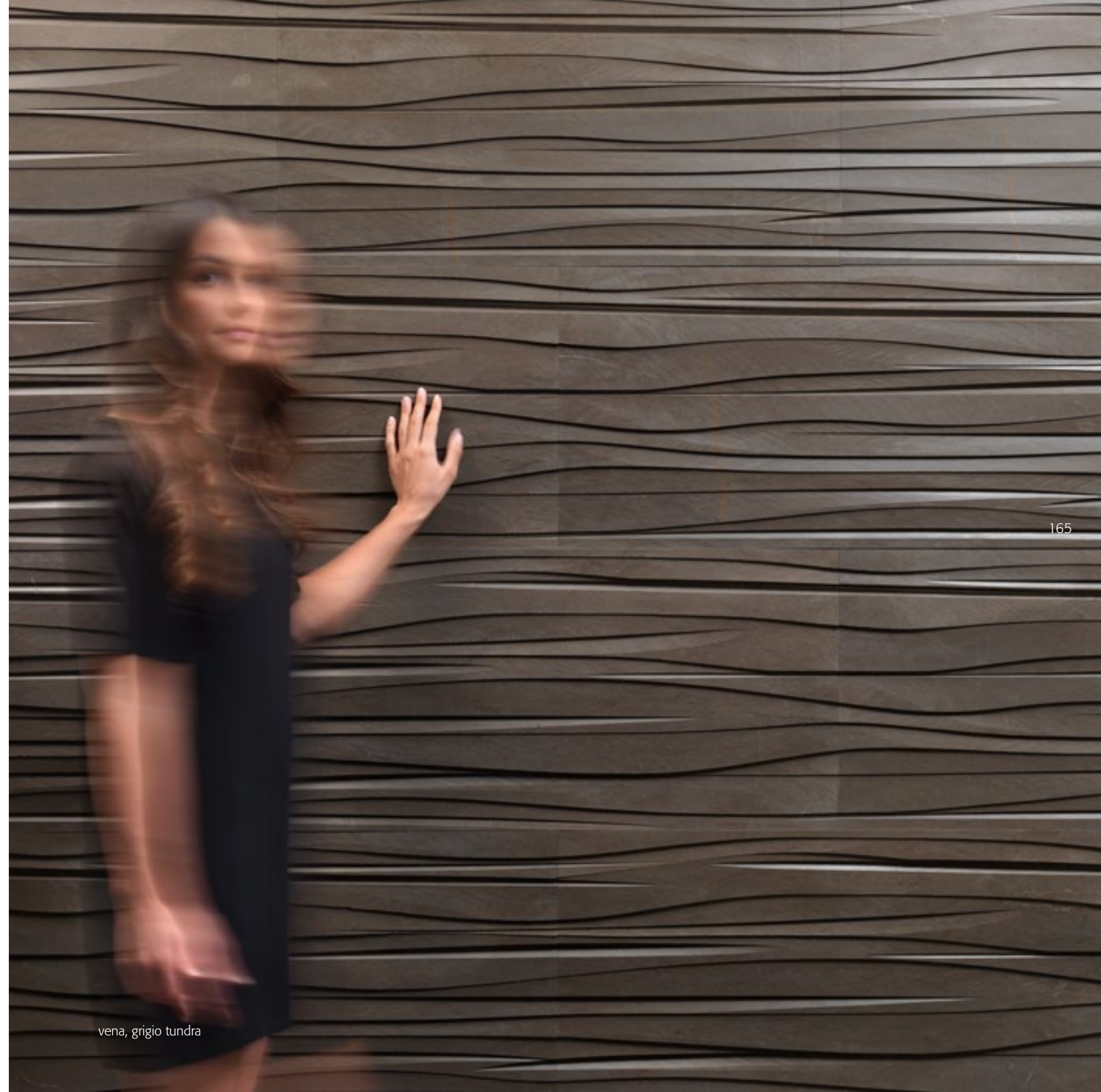

vena, grigio tundra

vena, grigio tundra

# scorcio

NUANCE

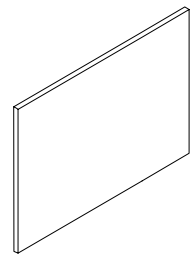

nuance  
80x40x2 cm



scorcio, botticino vaniglia

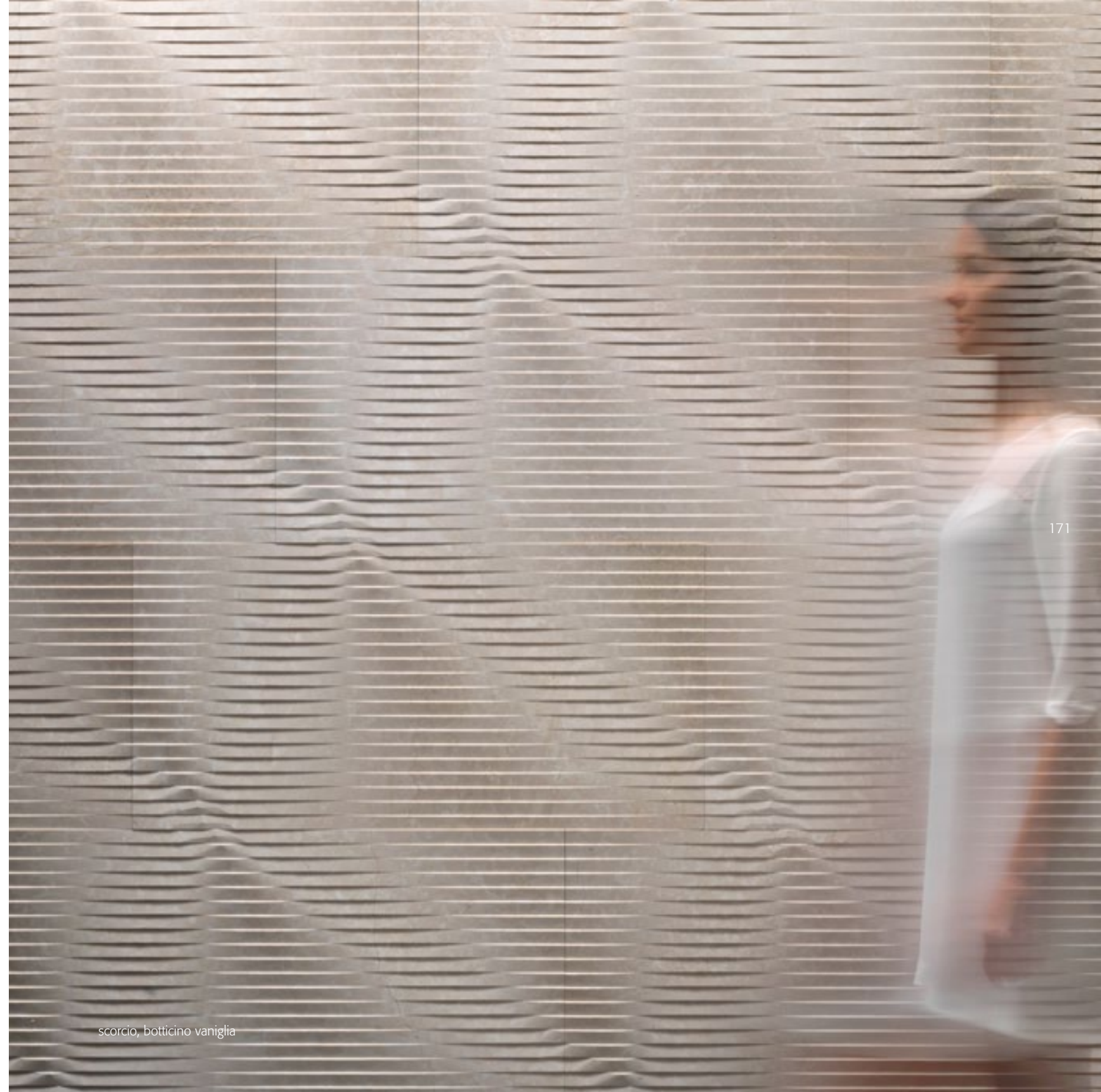

scorcio, botticino vaniglia





174

# crine

NUANCE

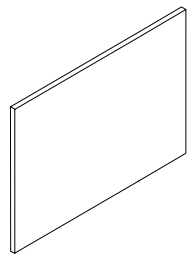

nuance  
80x40x2 cm

bianco cotone    botticino vaniglia    carrara ghiaccio    beige canapa    grigio tundra

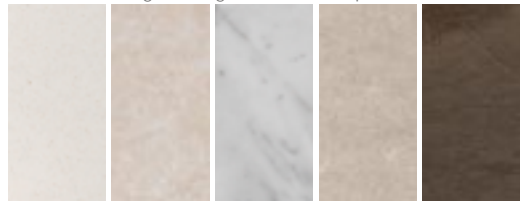

175

crine, bianco cotone



crine, bianco cotone





LE PIETRE LUMINOSE

# LE PIETRE LUMINOSE

Una nuova configurazione di prodotto 'chiavi in mano', un rivestimento lapideo modulare in 3D retroilluminato dove la luce si fa disegno e il disegno guida la luce ad affascinanti effetti lucenti e ornamentali.

La collezione nasce dalla sofisticata unione fra design, lavorazione di superficie e approfonditi studi illuminotecnici applicati alle proprietà traslucenti del marmo. Otto nomi di stelle per altrettanti rivestimenti luminosi, ritmati da un design all-over studiato in funzione della loro modularità e polifunzionalità. Tutti i modelli hanno infatti una resa estetica polivalente: di forte impatto anche senza retroilluminazione, assumono la loro massima espressione com-

binando retroilluminazione e luce radente. Ogni modulo è dotato di un apparato illuminotecnico indipendente, che rende pratica e agevole la normale manutenzione e garantisce una retroilluminazione uniforme a tutta la parete per una resa estetica impeccabile.

Con Le Pietre Luminose la parete prende vita. La luce incanta ed esalta ogni sfaccettatura del disegno, percorre e rivela ogni differenza di inclinazione, di spessore e incisione della pietra, attraversa l'elemento naturale svelando la sua anima più sensuale e intima. Il marmo così si rivela, armonizza le stratificazioni, scopre colori inattesi restituendo luce dolce e soffusa all'ambiente, che acquista una forte personalità scenica.

*A new, turnkey product configuration, a backlit modular 3D stone covering, where light drives the design and the design directs the light into fascinating luminous and ornamental effects.*

*The collection was born from the sophisticated combination of design, surface processing and thorough research into illumination techniques applied to the translucent properties of marble. Eight names of stars for eight luminous coverings, whose all-over patterns were studied taking into account their modularity and multi-functionality. Indeed, each texture provides a multi-purpose aesthetic effect: it has a strong impact even without back-lighting, and produces its maximum expression when back*

*light and grazing light are combined. Each module is equipped with an independent luminaire, ensuring that normal maintenance is practical and easy, and that the back-lighting is uniform for an impeccable aesthetic result. With Le Pietre Luminose, walls spring to life. Light enhances every facet of the design, goes all over and reveals every difference in the slope, in the thickness and in the cut of the stone, passes through the natural element revealing its most sensual and intimate soul. Marble is thus fully revealed, it shows off the harmony of its inner layers and displays unexpected colours as it returns a soft and suffused light to its surroundings, which in turn acquire a strong scenic personality of their own.*

# antares

LE PIETRE LUMINOSE

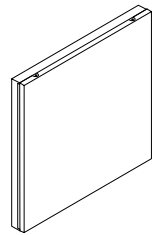

pietre luminose  
60x60x5 cm

carrara  
ghiaccio

rosa  
agata

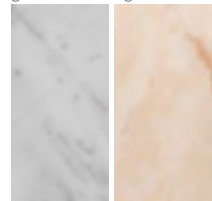

antares, rosa agata

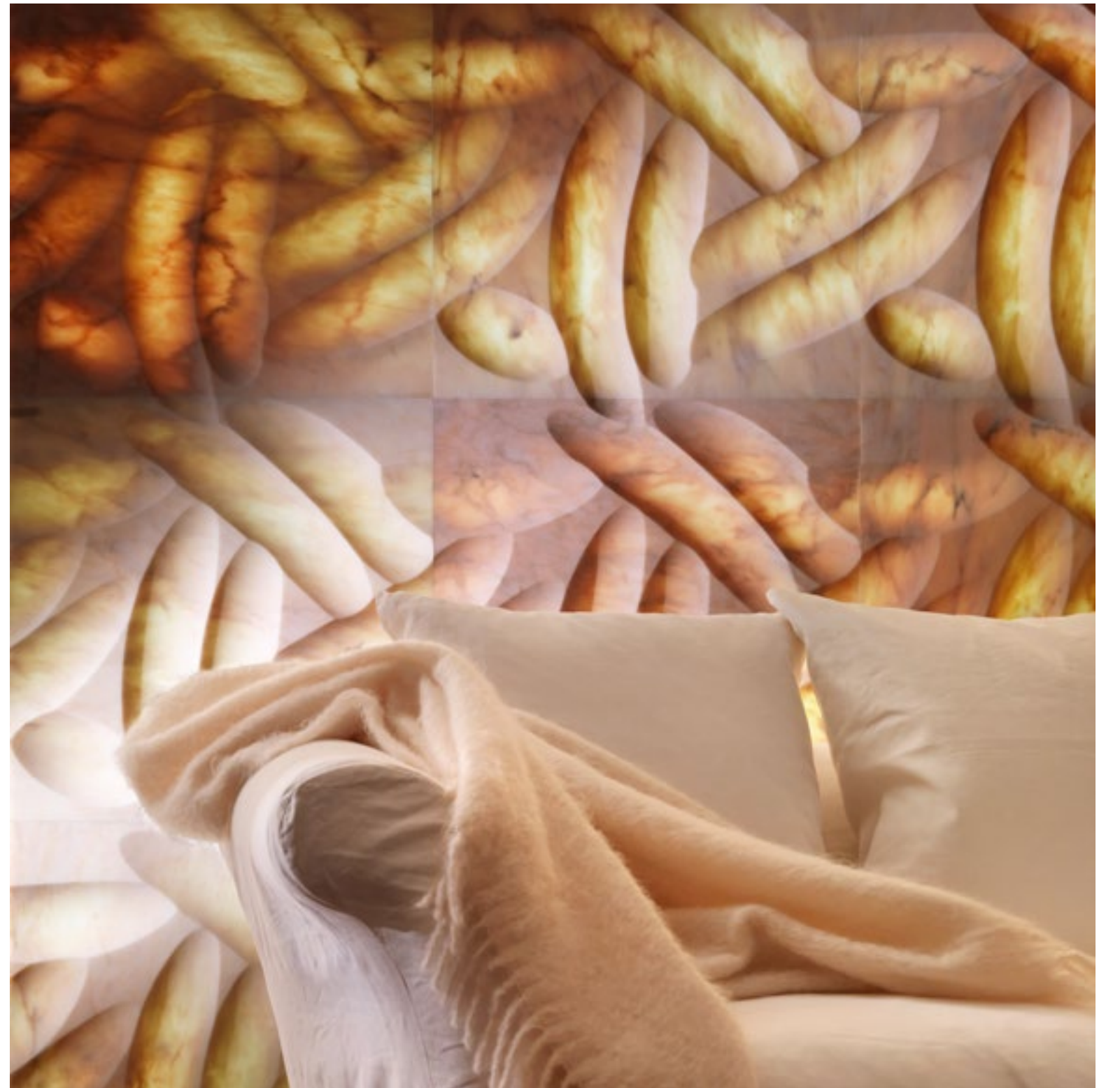





188



189

antares, rosa agata

190

# alcor

LE PIETRE LUMINOSE

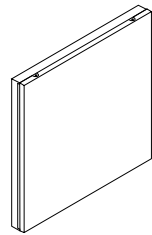

pietre luminose  
60x60x5 cm

carrara  
ghiaccio

rosa  
agata

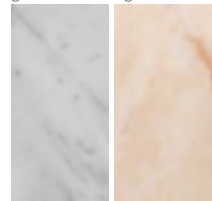

191

alcor, carrara ghiaccio



alcor, carrara ghiaccio





# naos

LE PIETRE LUMINOSE

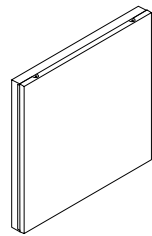

pietre luminose  
60x60x5 cm

carrara  
ghiaccio

rosa  
agata

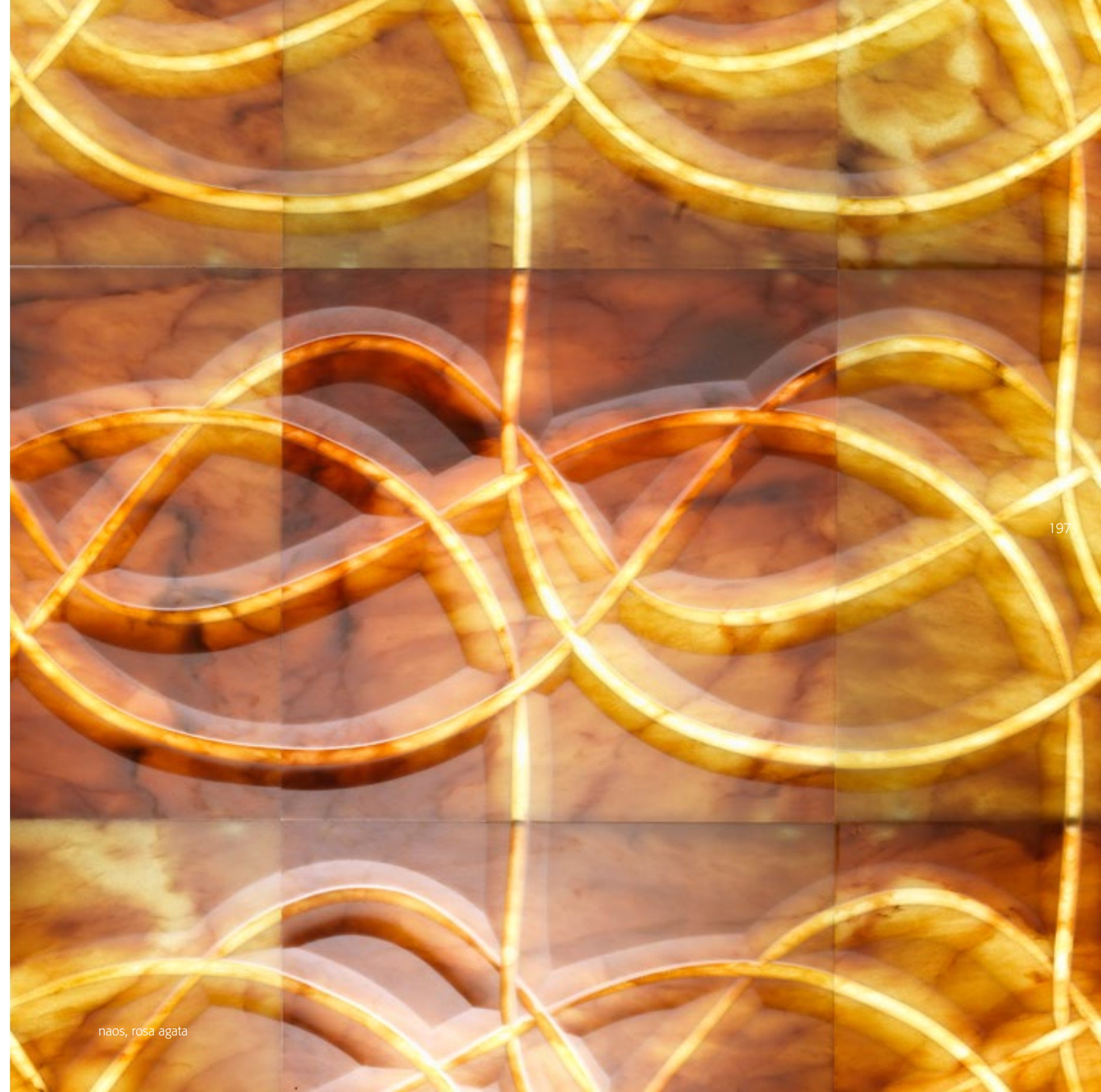
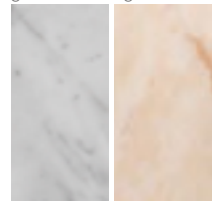

naos, rosa agata



# mizar

LE PIETRE LUMINOSE

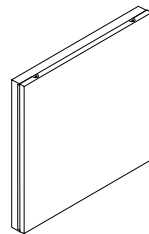

pietre luminose  
60x60x5 cm

carrara  
ghiaccio



rosa  
agata

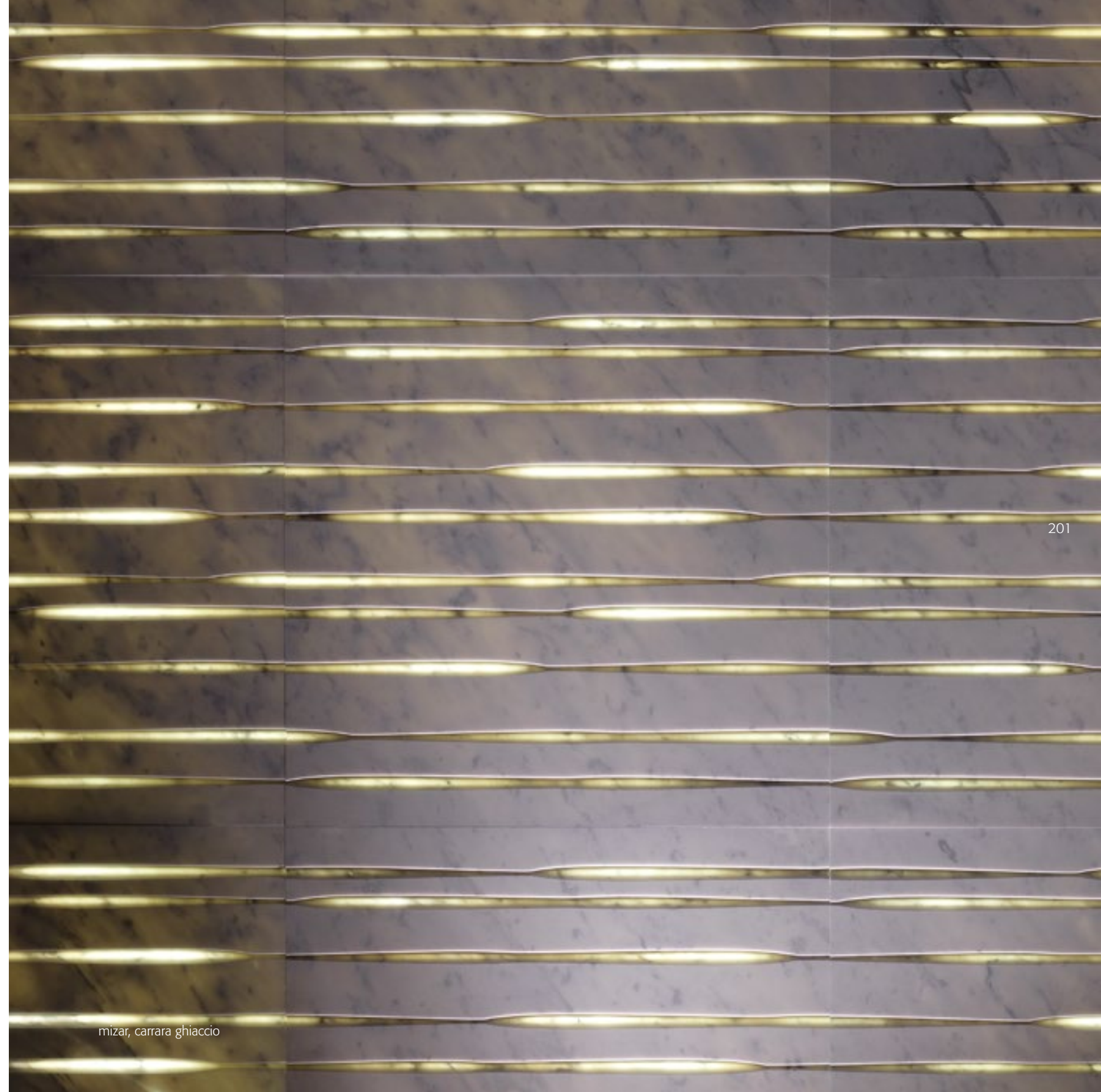

mizar, carrara ghiaccio

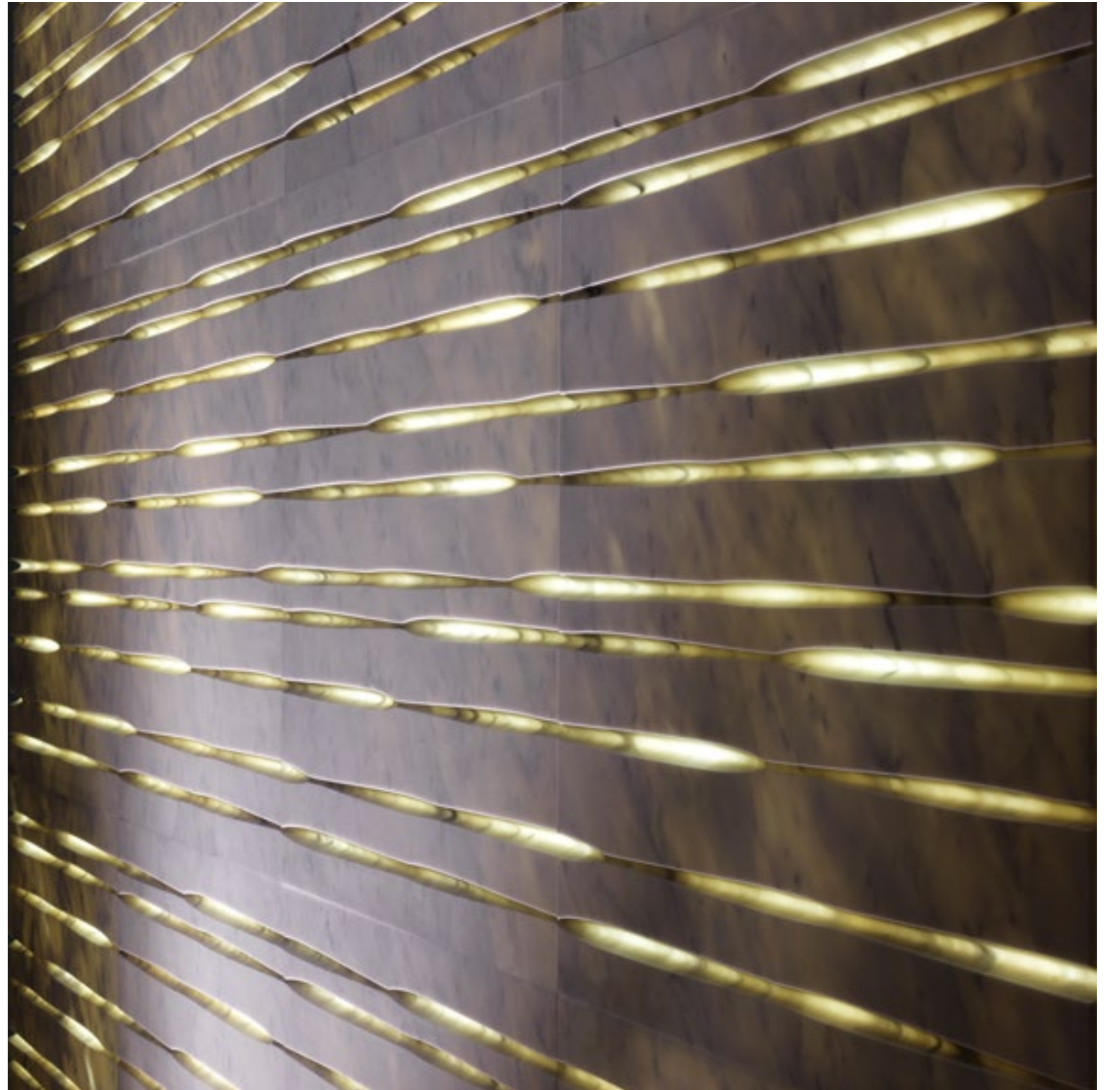
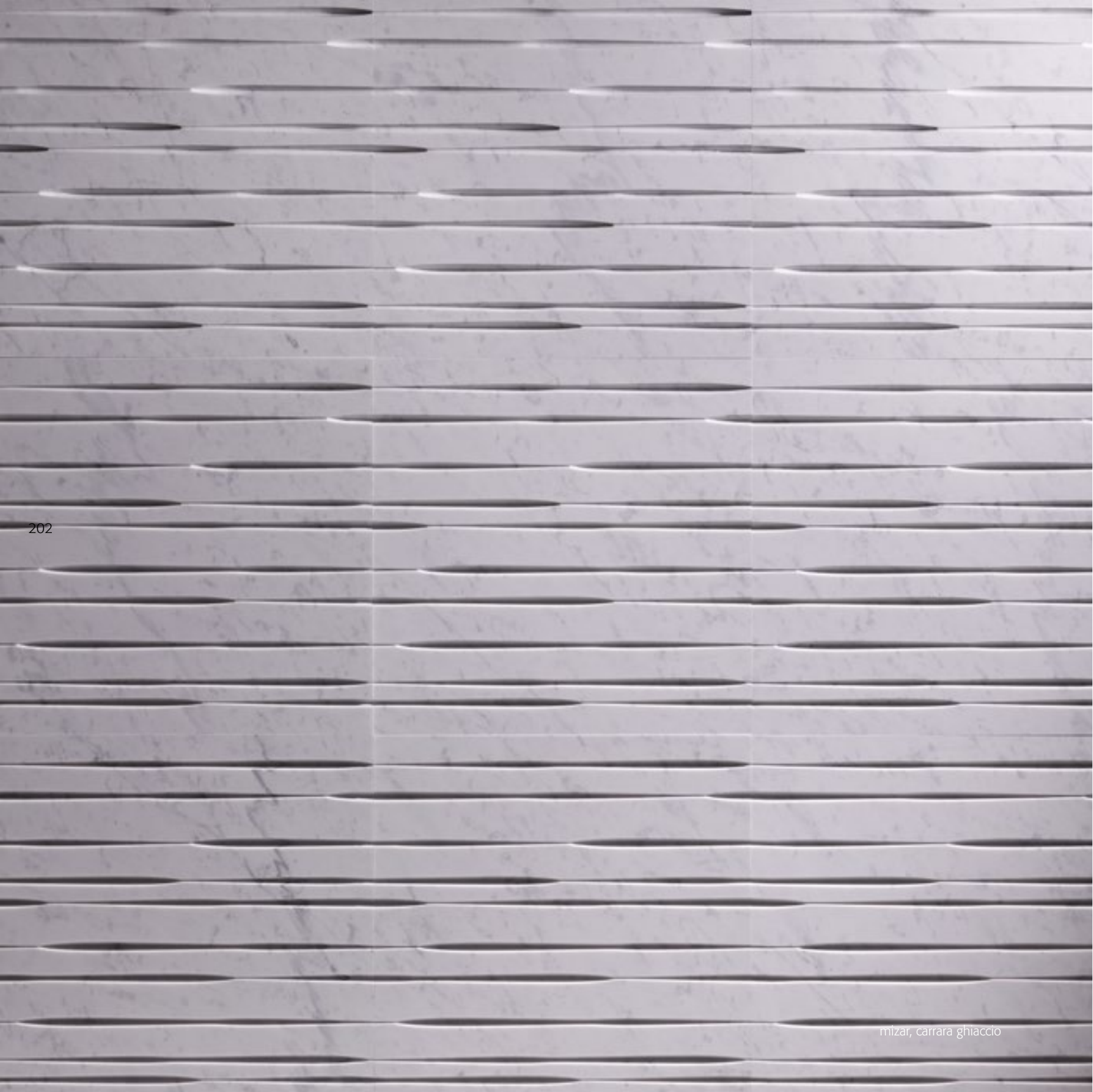





© copyright Aster

204



mizar, carrara ghiaccio

205

# sirio

LE PIETRE LUMINOSE

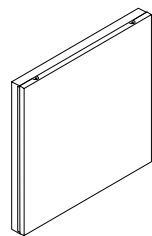

pietre luminose  
60x60x5 cm

carrara  
ghiaccio

rosa  
agata

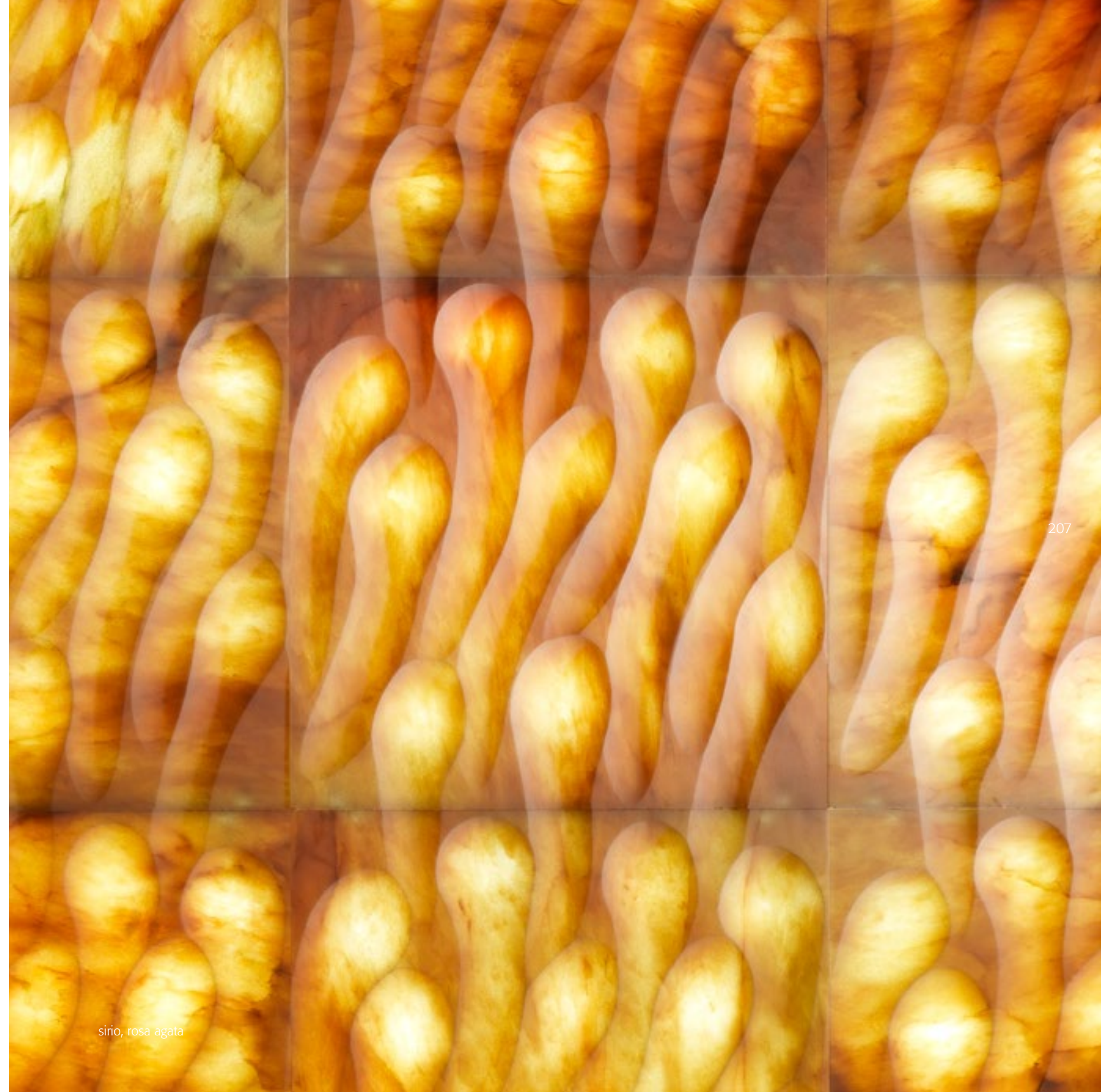
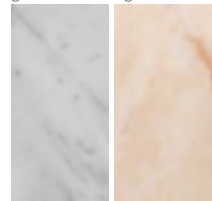

sirio, rosa agata



sirio, rosa agata



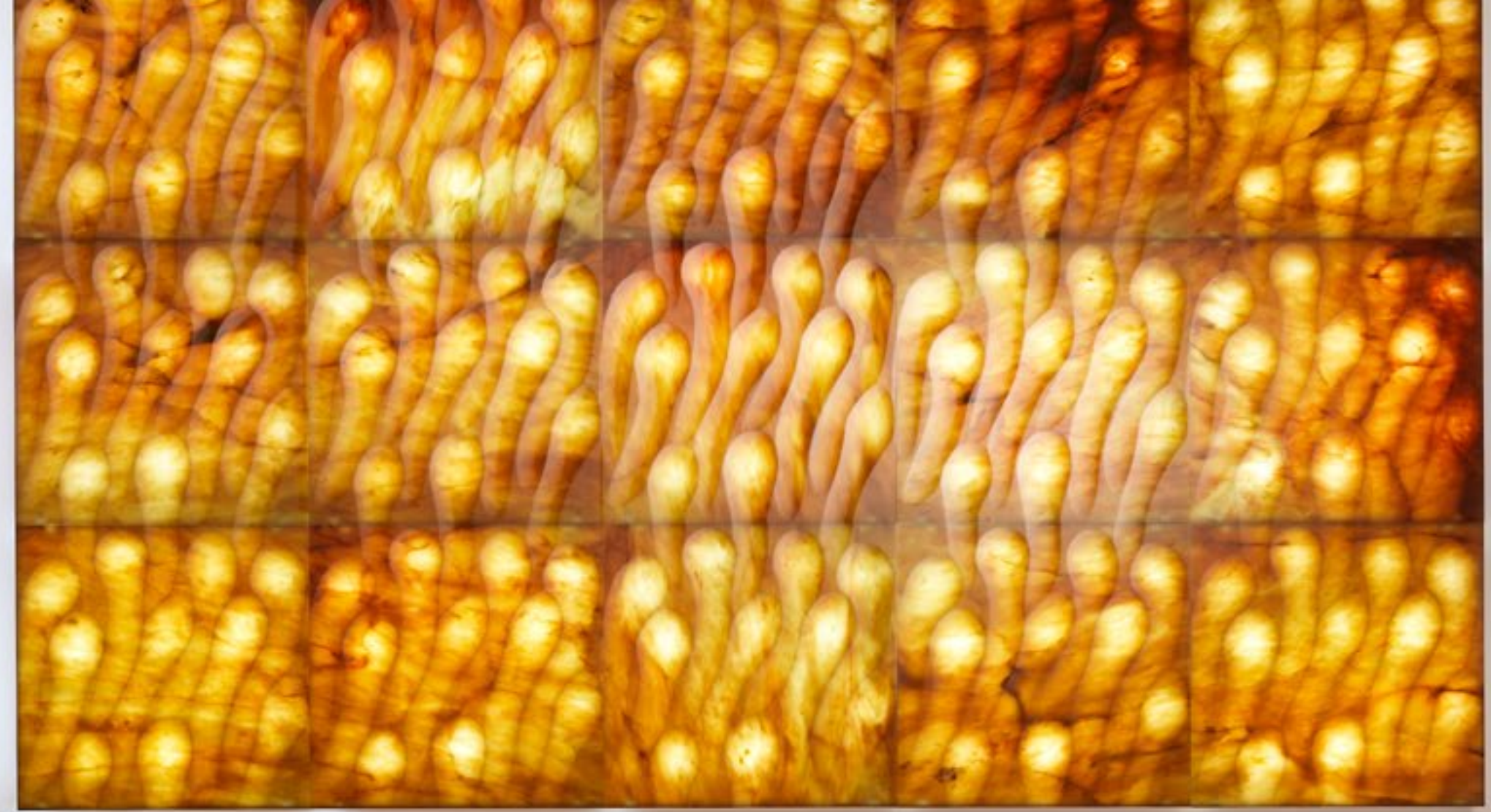

sirio, rosa agata

212

# polare

LE PIETRE LUMINOSE

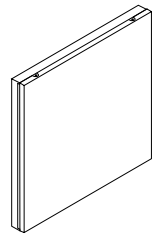

pietre luminose  
60x60x5 cm

carrara  
ghiaccio

rosa  
agata

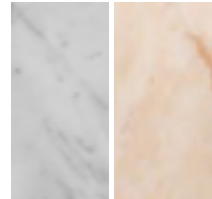

213



polare, carrara ghiaccio





216



217

polare, carrara ghiaccio

# vega

LE PIETRE LUMINOSE

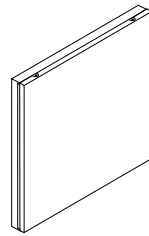

pietre luminose  
60x60x5 cm

carrara  
ghiaccio    rosa  
agata

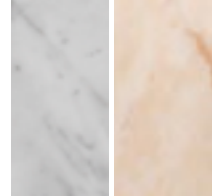

vega, rosa agata



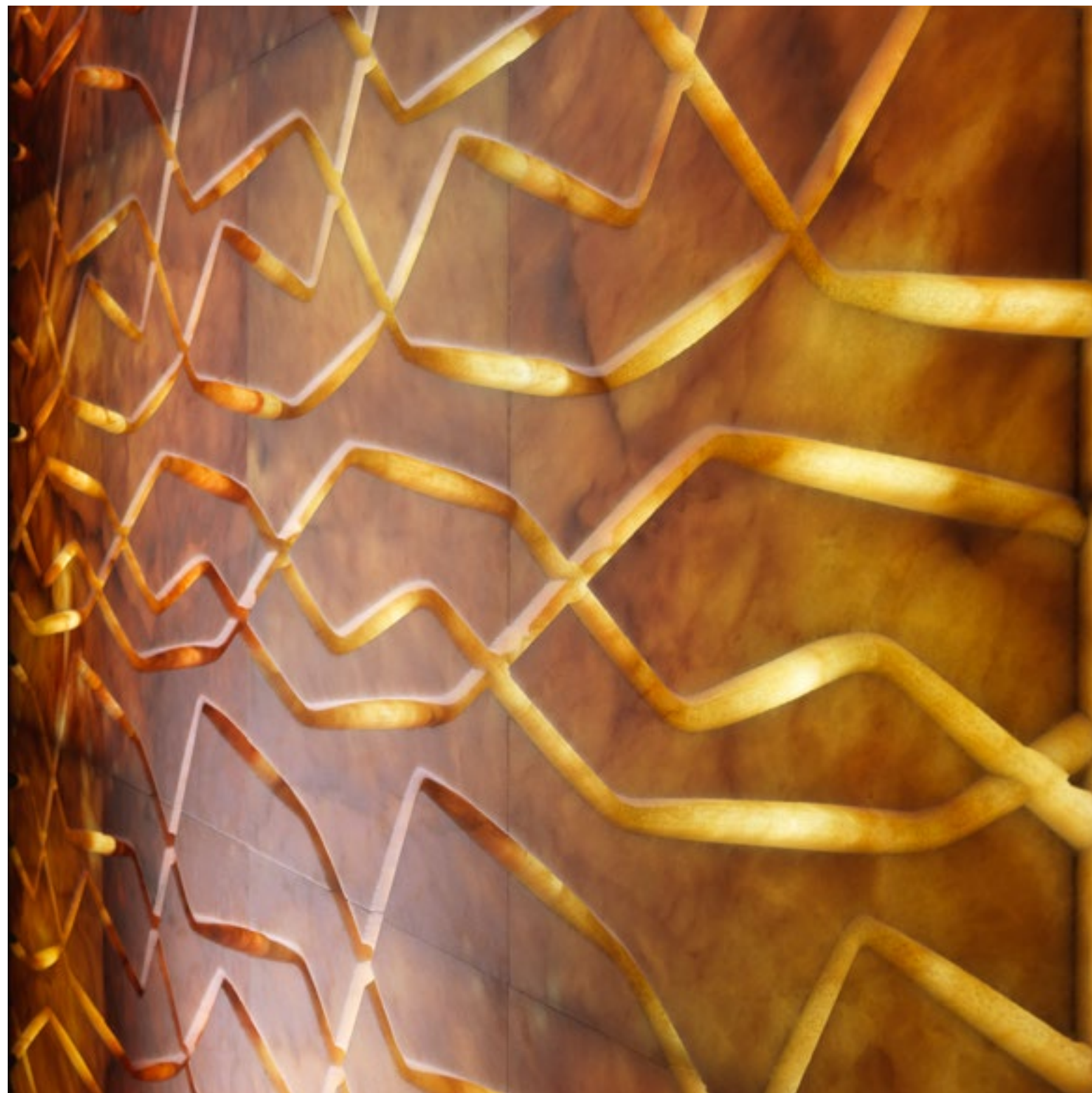



224

# rigel

LE PIETRE LUMINOSE

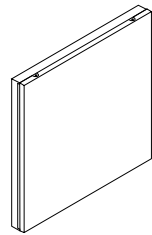

pietre luminose  
60x60x5 cm

carrara  
ghiaccio

rosa  
agata

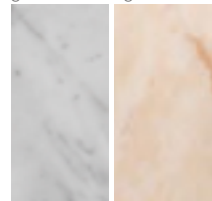

225



rigel, carrara ghiaccio



rigel, carrara ghiaccio





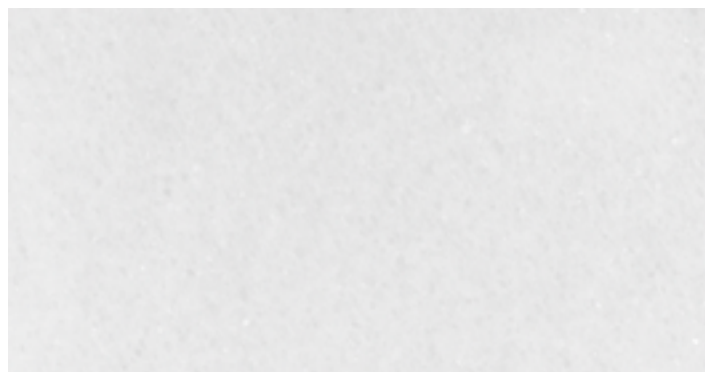

### bianco narciso

tipologia: marmo  
 applicazioni: rivestimenti verticali, pavimenti  
 peso per unità volume: 2740 kg/m<sup>3</sup>  
 percentuale assorbita d'acqua: 0,98 %  
 carico di rottura a compressione: 1260 kg/cm<sup>2</sup>

type: marble  
 applications: wall coverings, floors  
 weight per unit volume: 2740 kg/m<sup>3</sup>  
 water absorption: 0,98 %  
 compression breaking load: 1260 kg/cm<sup>2</sup>

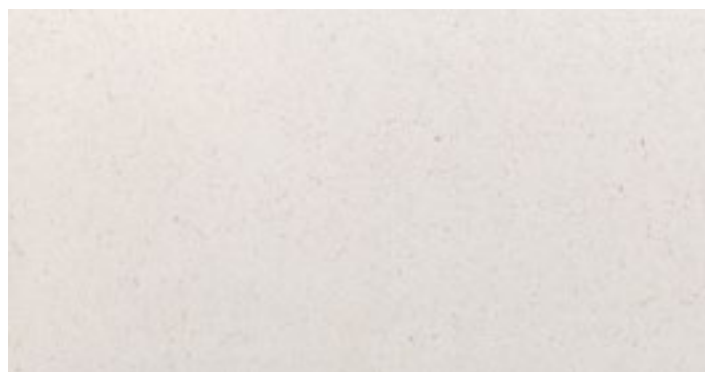

### bianco cotone

tipologia: limestone  
 applicazioni: rivestimenti verticali  
 peso per unità volume: 2500 kg/m<sup>3</sup>  
 percentuale assorbita d'acqua: 1,50 %  
 carico di rottura a compressione: -

type: limestone  
 applications: wall coverings  
 weight per unit volume: 2500 kg/m<sup>3</sup>  
 water absorption: 1,50 %  
 compression breaking load: -



### bianco pastello

tipologia: marmo  
 applicazioni: rivestimenti verticali, pavimenti  
 peso per unità volume: 2650 kg/m<sup>3</sup>  
 percentuale assorbita d'acqua: 1,50 %  
 carico di rottura a compressione: 1700 kg/cm<sup>2</sup>

type: marble  
 applications: wall coverings, floors  
 weight per unit volume: 2650 kg/m<sup>3</sup>  
 water absorption: 1,50 %  
 compression breaking load: 1700 kg/cm<sup>2</sup>

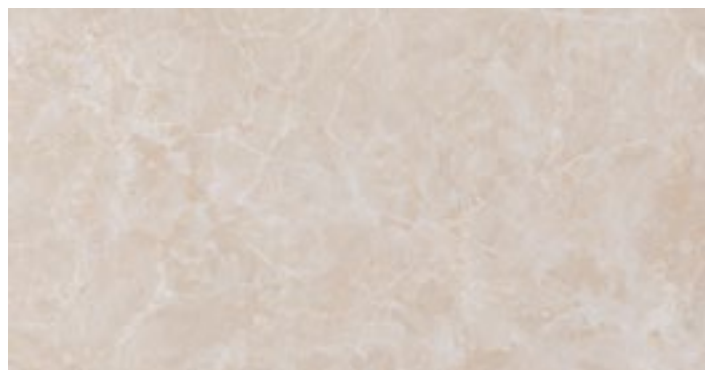

### botticino vaniglia

tipologia: marmo  
 applicazioni: rivestimenti verticali, pavimenti  
 peso per unità volume: 2590 kg/m<sup>3</sup>  
 percentuale assorbita d'acqua: 1,10 %  
 carico di rottura a compressione: -

type: marble  
 applications: wall coverings, floors  
 weight per unit volume: 2590 kg/m<sup>3</sup>  
 water absorption: 1,10 %  
 compression breaking load: -



### rosa agata

tipologia: marmo  
 applicazioni: rivestimenti verticali, pavimenti  
 peso per unità volume: 2715 kg/m<sup>3</sup>  
 percentuale assorbita d'acqua: 1,50 %  
 carico di rottura a compressione: 1350 kg/cm<sup>2</sup>

type: marble  
 applications: wall coverings, floors  
 weight per unit volume: 2715 kg/m<sup>3</sup>  
 water absorption: 1,50 %  
 compression breaking load: 1350 kg/cm<sup>2</sup>



### carrara ghiaccio

tipologia: marmo  
 applicazioni: rivestimenti verticali, pavimenti  
 peso per unità volume: 2550 kg/m<sup>3</sup>  
 percentuale assorbita d'acqua: 0,93 %  
 carico di rottura a compressione: 1309 kg/cm<sup>2</sup>

type: marble  
 applications: wall coverings, floors  
 weight per unit volume: 2550 kg/m<sup>3</sup>  
 water absorption: 0,93 %  
 compression breaking load: 1309 kg/cm<sup>2</sup>

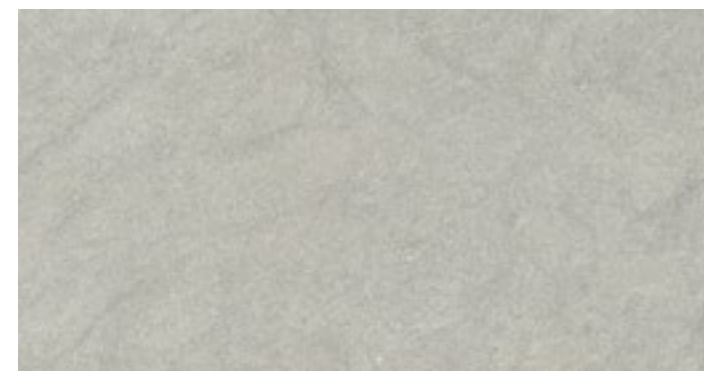

### grigio cenere

tipologia: limestone  
 applicazioni: rivestimenti verticali  
 peso per unità volume: 2450 kg/m<sup>3</sup>  
 percentuale assorbita d'acqua: 1,50 %  
 carico di rottura a compressione: -

type: limestone  
 applications: wall coverings  
 weight per unit volume: 2450 kg/m<sup>3</sup>  
 water absorption: 1,50 %  
 compression breaking load: -

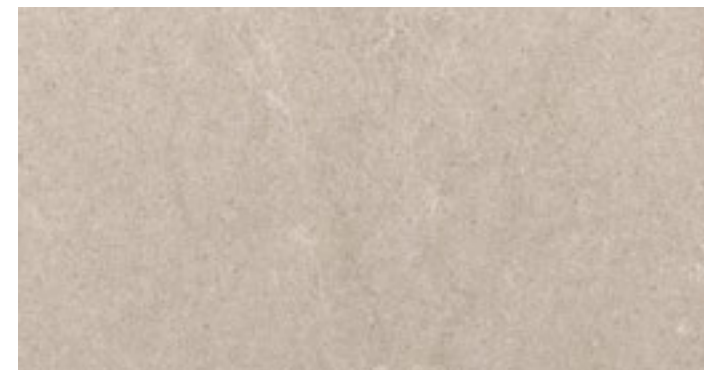

### beige canapa

tipologia: limestone  
 applicazioni: rivestimenti verticali  
 peso per unità volume: 2680 kg/m<sup>3</sup>  
 percentuale assorbita d'acqua: 1,25 %  
 carico di rottura a compressione: -

type: limestone  
 applications: wall coverings  
 weight per unit volume: 2680 kg/m<sup>3</sup>  
 water absorption: 1,25 %  
 compression breaking load: -

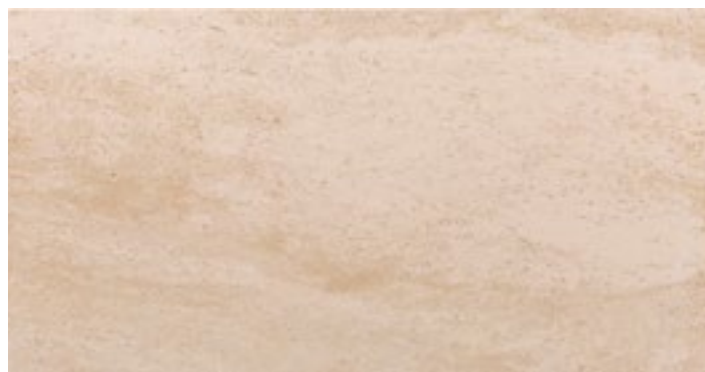

### ocra sabbia

tipologia: limestone  
 applicazioni: rivestimenti verticali  
 peso per unità volume: 2300 kg/m<sup>3</sup>  
 percentuale assorbita d'acqua: -  
 carico di rottura a compressione: -

type: limestone  
 applications: wall coverings  
 weight per unit volume: 2300 kg/m<sup>3</sup>  
 water absorption: -  
 compression breaking load: -

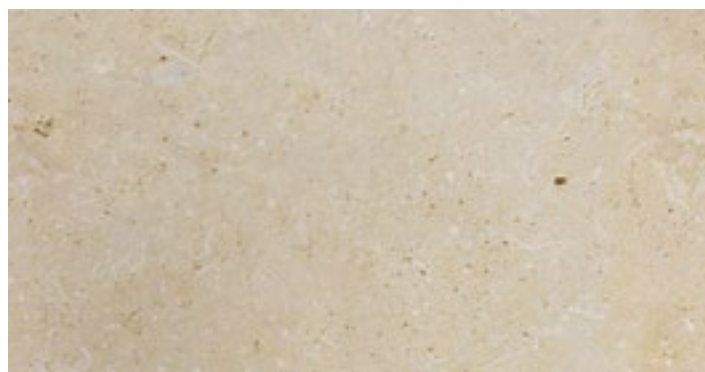

### giallo dorato

tipologia: limestone  
 applicazioni: rivestimenti verticali, pavimenti  
 peso per unità volume: 2000 kg/m<sup>3</sup>  
 percentuale assorbita d'acqua: 10,0 %  
 carico di rottura a compressione: -

type: limestone  
 applications: wall coverings, floors  
 weight per unit volume: 2000 kg/m<sup>3</sup>  
 water absorption: 10,00 %  
 compression breaking load: -

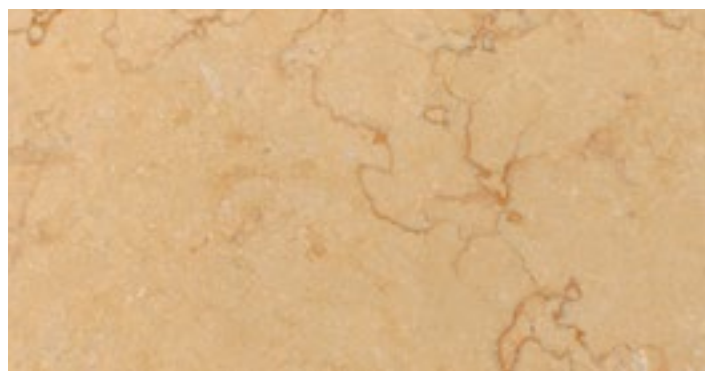

### silva oro

tipologia: marmo  
 applicazioni: rivestimenti verticali, pavimenti  
 peso per unità volume: 2260 kg/m<sup>3</sup>  
 percentuale assorbita d'acqua: 1,7 %  
 carico di rottura a compressione: -

type: marble  
 applications: wall coverings, floors  
 weight per unit volume: 2260 kg/m<sup>3</sup>  
 water absorption: 1,7 %  
 compression breaking load: -

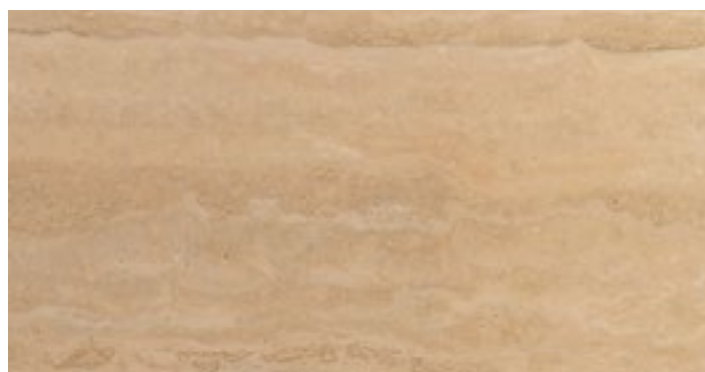

### travertino latino

tipologia: travertino  
 applicazioni: rivestimenti verticali, pavimenti  
 peso per unità volume: 2447 kg/m<sup>3</sup>  
 percentuale assorbita d'acqua: 0,89 %  
 carico di rottura a compressione: 1213 kg/cm<sup>2</sup>

type: travertine  
 applications: wall coverings, floors  
 weight per unit volume: 2447 kg/m<sup>3</sup>  
 water absorption: 0,89 %  
 compression breaking load: 1213 kg/cm<sup>2</sup>

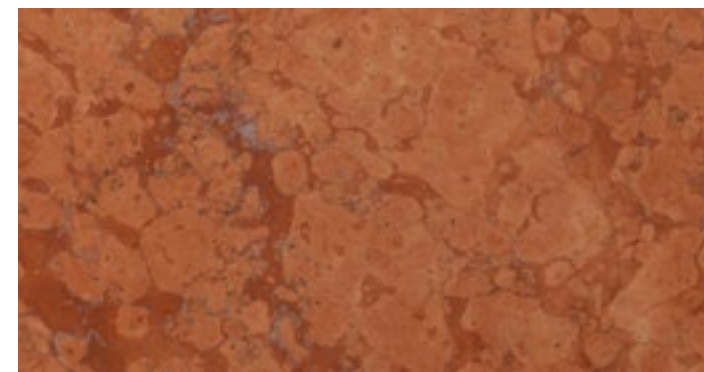

### rosso pastello

tipologia: marmo  
 applicazioni: rivestimenti verticali, pavimenti  
 peso per unità volume: 2680 kg/m<sup>3</sup>  
 percentuale assorbita d'acqua: 1,60 %  
 carico di rottura a compressione: 1625 kg/cm<sup>2</sup>

type: marble  
 applications: wall coverings, floors  
 weight per unit volume: 2680 kg/m<sup>3</sup>  
 water absorption: 1,60 %  
 compression breaking load: 1625 kg/cm<sup>2</sup>



### rosa dolomiti

tipologia: marmo  
 applicazioni: rivestimenti verticali, pavimenti  
 peso per unità volume: 2690 kg/m<sup>3</sup>  
 percentuale assorbita d'acqua: 1,10 %  
 carico di rottura a compressione: 1400 kg/cm<sup>2</sup>

type: marble  
 applications: wall coverings, floors  
 weight per unit volume: 2690 kg/m<sup>3</sup>  
 water absorption: 1,10 %  
 compression breaking load: 1400 kg/cm<sup>2</sup>



### grigio tundra

tipologia: marmo  
 applicazioni: rivestimenti verticali, pavimenti  
 peso per unità volume: 2510 kg/m<sup>3</sup>  
 percentuale assorbita d'acqua: 3,20 %  
 carico di rottura a compressione: -

type: marble  
 applications: wall coverings, floors  
 weight per unit volume: 2510 kg/m<sup>3</sup>  
 water absorption: 3,20 %  
 compression breaking load: -

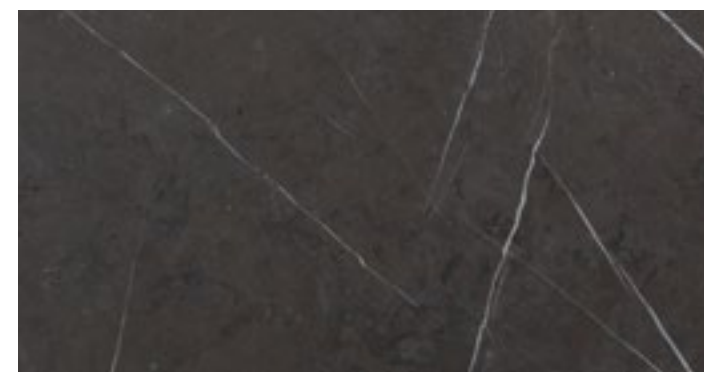

### gris st pierre

tipologia: marmo  
 applicazioni: rivestimenti verticali, pavimenti  
 peso per unità volume: 2680 kg/m<sup>3</sup>  
 percentuale assorbita d'acqua: 1,20 %  
 carico di rottura a compressione: -

type: marble  
 applications: wall coverings, floors  
 weight per unit volume: 2680 kg/m<sup>3</sup>  
 water absorption: 1,20 %  
 compression breaking load: -



## pierre bleue

tipologia: marmo  
applicazioni: rivestimenti verticali, pavimenti  
peso per unità volume: 2686 kg/m<sup>3</sup>  
percentuale assorbita d'acqua: -  
carico di rottura a compressione: 1200 kg/cm<sup>2</sup>

type: marble  
applications: wall coverings, floors  
weight per unit volume: 2686 kg/m<sup>3</sup>  
water absorption: -  
compression breaking load: 1200 kg/cm<sup>2</sup>

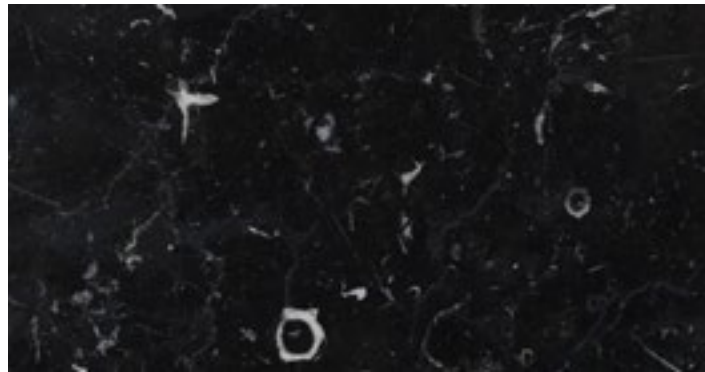







## nero marquina

tipologia: marmo  
applicazioni: rivestimenti verticali, pavimenti  
peso per unità volume: 2700 kg/m<sup>3</sup>  
percentuale assorbita d'acqua: 0,90%  
carico di rottura a compressione: 1428 kg/cm<sup>2</sup>

type: marble  
applications: wall coverings, floors  
weight per unit volume: 2700 kg/m<sup>3</sup>  
water absorption: 0,90%  
compression breaking load: 1428 kg/cm<sup>2</sup>



LE PIETRE INCISE

-  10 diamante
-  16 tropico
-  22 palma
-  28 sahara
-  34 seta
-  46 fondo
-  60 tratto
-  74 quadro
-  78 favo
-  86 cubo
-  92 lembo
-  96 terra
-  100 virgola
-  104 giza



-  108 doge
-  110 gemma
-  112 prisma

LE PIETRE INCISE PALLADIO

-  118 palladio RV2
-  126 palladio RV6
-  132 palladio RV3
-  136 palladio RV1
-  138 palladio RV7

NUANCE

-  144 tartan
-  150 vello
-  156 risma
-  162 vena

-  168 scorcio
-  174 crine

LE PIETRE LUMINOSE

-  184 antares
-  190 alcor
-  196 naos
-  200 mizar
-  206 sirio
-  212 polare
-  218 vega
-  224 rigel

229 materials

Page 41 project by  
10+design

Page 42-43; 44-45 project by  
ARCHPOINT  
archpoint.ru info@archpoint.ru  
Project: Baku Restaurant - Moscow  
Valery Lizunov - chief architect, workshop leader  
Maxim Vinokurov - architect  
Ekaterina Ageeva - design, decoration  
Ivan Sorokin - photo  
© Archpoint all rights reserved

Page 48-49; 50; 88-91 project by  
LONGO PALMARINI ARCHITECTURE & PARTNERS  
www.lparchitecture.it info@lparchitecture.it  
Project: Residence Le Provençal – Cap D'Antibes  
© Longo Palmarini Architecture & Partners all rights reserved

Page 51; 54-55; 66; 67; 134-135 projects by  
STONE GROUP AG  
www.stonegroup.ch info@stonegroup.ch  
© Stone Group AG all rights reserved

Page 52-53 project by  
DRIUSSOASSOCIATI | ARCHITECTS  
www.driussoassociati.com driussoassociati@gmail.com  
Project: Marciana Restaurant - Venice  
© Marciana Restaurant all rights reserved

Page 94-95 project by  
Studio D73 and Wellness today - Happy Sauna Group  
www.d73.it info@d73.it  
www.wellnesstoday.it  
Project: Golden Mile - Moscow  
Interior design: Arch. Marco Vismara - Arch. Andrea Viganò  
© Golden Mile all rights reserved

Page 98-99 project by  
A-OMA  
www.a-oma.eu info@a-oma.eu  
Project: Villa A  
Architect: Alfio Faro  
© A-OMA all rights reserved

Page 102-103 project by  
MAS ARCHITECTURE  
www.masarchitecture.co.uk info@masarchitecture.co.uk  
Project: Ritz Carlton exteriors – Bahrain  
Architects: Maan Alsalloum - Dalia Almardi  
©MAS ARCHITECTURE all rights reserved

Page 124-125 pictures courtesy of  
Molteni&C  
www.molteni.it

Page 199 project by  
Frank Theuerkauf  
www.frank-theuerkauf.de info@frank-theuerkauf.de  
Project: THE ROOM Bar & Club – Hamburg  
©Frank Theuerkauf all rights reserved

Page 204-205 pictures courtesy of  
Aster Cucine  
www.astercucine.it  
Art Direction: Studio Lorenzo Granocchia

AVVERTENZE	DIRECTIONS	NOTICES EXPLICATIVES	HINWEISE	ADVERTENCIAS	PRIMECHANIA
<p>I materiali utilizzati per i prodotti Lithos Design srl sono pietre e marmi naturali, soggetti a variazioni più o meno accentuate di tono e con magrosità e piccoli fori; questi sono da considerarsi come pregi e caratteristiche intrinseche del materiale. Le operazioni di decorazione, doratura e laccatura del marmo per la linea ‘Luxury’ sono realizzate in maniera artigianale, utilizzando prodotti di origine italiana. Variazioni nella tonalità dei colori sono da considerarsi una caratteristica naturale ed artistica che contribuisce a rendere il prodotto unico ed originale. Nella continua ricerca di miglioramenti tecnici e funzionali, Lithos Design srl si riserva il diritto di apportare modifiche -anche sostanziali e senza preavviso- ai propri prodotti. Le foto ed i campioni forniti dalla Lithos Design srl sono da considerarsi puramente indicativi e non possono in nessun caso essere considerati vincolanti. Il presente catalogo è tutelato dalla legge sui diritti d’autore (legge 22/04/1941 n.663 e dalla legge 14/12/1942 n.1485). Di esso è proibita ogni riproduzione totale o parziale.</p>	<p>The materials used by Lithos Design srl are marble and stone and, like all natural products, are subject to more or less accentuated variations in colour and may present minute excoriations and tiny holes; these are to be considered merits and intrinsic characteristics of the material. Decorations, gold finishings and lacquering of marble for the ‘Luxury’ line are craftmade, using only materials of italian origin. Variations in tonalities of the colours must be considered a natural and artistic characteristics that contribute to make these items unique and original. In the interest of ongoing aimed at improving technical features and product performance, Lithos Design srl reserves the right to alter, even substantially, its products without prior notification. Pictures and samples provided by Lithos Design srl are purely indicative and are not to be considered as binding in any way. This catalogue is safeguarded by copyright law (law n. 633 of 22/04/1941 and law n.1485 of 14/12/1942) and as such it is strictly forbidden to reproduce or copy either fully or partially any of the content herein.</p>	<p>Les matériaux utilisés par Lithos Design srl sont pierres naturelles et marbres, et, comme tous les produits naturels, sont sujet à des variations plus ou moins accentuées de la tonalité et peuvent présenter des imperfections superficielles et des petits trous qui doivent etre considérés comme des qualités et caractéristiques intrinsèques de la matière. La décoration du marbre, dorure et lacage de la ligne ‘Luxury’ sont réalisés artisanalment avec produits d’origine italienne. D’éventuelles variations dans la nuance des couleurs constituent une caractéristique naturelle et artistique qui contribue à rendre le produit unique et original. Dans le cadre d’une recherche continue d’améliorations techniques et fonctionnelles, Lithos Design srl se réserve le droit d’apporter des modifications, même ubstantielles, à ses produits, qui pourront etre effectuées sans préavis. Les couleurs des reproductions photographiques et les échantillons doivent etre considérées comme indicatifs et ne sont pas ontraignantes pour Lithos Design srl. Le présent catalogue est protégé par la loi sur les droits d’auteur (loi 22/4/1941 n.633 et par la loi 14/12/1942 n.1485). Sa reproduction totale ou même partielle est interdite.</p>	<p>Das Materialien verwendet von Lithos Design srl sind Steine und natürlich Marmor. Wie alle Naturprodukte, dies Materialien haben mehr oder weniger akzentuirten Farbtonvariationen. Er kann kleine Löcher und Megerzonen aufweisen. Diese gelten als dem Materialien eigene Merkmale und Vorteile. Die von Lithos Design srl gelieferten Abbildungen uns Muster sind daher immer rein richtungswaisend und können auf klein Fall als binden gewerten werden. Alle kunsthandwerkliche Materialien die zur Verzierung unserer Naturstein verwendet werden sind italienischen Ursprungs. Farbdifferenzen die zwischen den einzelnen Artikeln auftreten, sind Charakteristiken der von Hand gemachten Dekorationen welche diese einzigartig machen. Lithos Design srl behalt sich, zwecks technischer oder funktio-neller Produktverbesserungen, auch wesentliche Abanderungender produkte ohne Vorwarnung durchzuführen. Es wird ausdrücklich keine Gewähr fur durchzuführen. Ubereinstimmung auf Farben der Bilder mit den Originalen geleistet. Dieser Katalog unterliegt den gesetzlichen Bestimmungen des Unheberrechtes (Gesetz 22/4/1941 Nr.663 und 14/12/1942 Nr.1485).</p>	<p>Los materiales utilizados en la realización de las líneas Lithos Design srl son piedra y mármol natural, son por lo tanto sujetos a variaciones más o menos acentuadas de tono y pueden presentar falta de compactibilidad y pequeños agujeros; éstos se deben considerar como calidades y características intrínsecas del material. Las operaciones de decoración, doradura y lacado de la línea ‘Luxury’ se realizan artesanalmente con productos de origen italiana. Variaciones en las tonalidades se tienen que considerar como características naturales y artísticas, que contribuyen a la unicidad y originalidad del producto. En la continua búsqueda de mejoras técnicas y funcionales, Lithos Design srl se reserva el derecho de hacer modificaciones, incluso sustanciales, en sus propios productos, que se podrían efectuar sin aviso previo. Las reproducciones fotográficas y las muestras se deben entender como indicativas y no son vinculantes para Lithos Design srl. Este catálogo está amparado por la ley sobre los derechos de autor (ley 22/04/1941 n. 633 y par la ley 14/12/1942 n. 1485) y se prohíbe cualquier reproducción total o parcial.</p>	<p>В материалах, используемых для продукции компании Lithos Design srl, могут встречаться вариации она, более или менее акцентированные, с пористостью и небольшими отверстиями, что является ценностью и особенностью присущей данному материалу. Операции по декорированию и позолоте изделий линии «Lухигу» выполнены ремесленным способом, с использованием продукции произведенной в Италии. Вариации оттенков цвета являются природной и художественной характеристикой, которая делает изделие уникальным и неповторимым. Постоянно стремясь к техническому и функциональному совершенствованию, Lithos Design оставляет за собой право вносить изменения, даже существенные и без предварительного извещения, в собственные изделия. Фото и образцы, предоставленные компанией Lithos Design, являются исключительно демонстративными и не в коем случае не могут рассматриваться как обязательные к исполнению. Настоящий каталог защищен законом об авторских правах (закон от 22.04.1941 № 663 и закон от 14.12.1942 №1485).Этим законом запрещается любое воспроизведение, частичное или полное.</p>
<p>I marchi e i modelli sono depositati</p>	<p>Trademarks and models are registered</p>	<p>Les marques et modèles sont déposés</p>	<p>Die Warenzeichen und die Modelle sind eingetragen</p>	<p>Las marcas y los modelos son depositados</p>	<p>Материалы и модели зарегистрированы.</p>





LITHOS DESIGN srl  
via Del Motto, 25 36070 San Pietro Mussolino (VI) Italy  
Tel. +39 0444 687301 Fax +39 0444 687398  
info@lithosdesign.com www.lithosdesign.com  
made in italy